

Cobalt

(YD30) Sideload Lock



The Cobalt is a motor driven electronic lock designed to secure commercial and residential double acting doors.

The lock addresses the two biggest issues in door locking; the ability to align a misaligned door, and the ability to release when requested even with excessive load on the door.

Reliable, secure, and convenient.

The Cobalt has arrived.



FEATURES

High Security

With two 10mm thick stainless steel bolt pins, the Cobalt has a holding force in excess of 10,000N. On-board control provides auto-relock for added security.

Sideload

The unique design of the Cobalt uses a collapsing mechanism that is deadbolted when locked, but will unlock when requested even with 1,000N of force on the door.

Alignment

The pivot action of the Cobalt bolt pins will grab the strike plate and pull the door into position for a misalignment up to 8mm in either direction.

Complete Monitoring

The Cobalt can output both the bolt position and the door position as monitor signals.

Low Current Consumption

The Cobalt will draw as little as 30mA in standby, and only 300mA in operation at 12VDC.

Integrated Access Control

With user selectable fail safe and fail secure modes, and multiple attempts to lock or unlock, the Cobalt is ready for a wide range of application requirements and can be integrated with many access control or alarm systems.

Versatile Installation

With the included fitting tabs the Cobalt can be morticed flush into both the side and top of many door frames. Optional housing and dress plate allow for surface mounting the lock and strike for an even wider range of applications, including installation on glass doors.

SPECIFICATIONS

Door Gap

6mm maximum

Static Strength

10,000 newtons (1,000Kg)

Sideload (release on request)

1,000 newtons (100Kg)

Endurance

Cycle tested to 300,000 operations

Bolt Pins (2 pieces)

10mm thick, 13mm extension, 14.2mm receiver

Alignment

±8mm misalignment correction

Voltage at Lock

12 - 24VDC ±15%

Current Usage

Standby: 40mA@12V, 30mA@24V

Maximum: 1.0A@12V, 0.5A@24V

Monitor Switch Ratings

24VDC, 0.25A

Materials

Lock / Strike Plate: Stainless Steel 304

Bolt Pin: Stainless Steel 17-4 PH

Compliance and Certification

CE Compliant, RoHS 2 Compliant

FCC Part 15 Compliant

EN 14846:2008 Certified

Suitable for use on fire resistant door-sets

Lock Variants

YNL200H – Lock with Long Strike Plate

Accessories

YNL203H – Long Strike Plate

YNL204J – Housing

YNL206J – Dress Plate

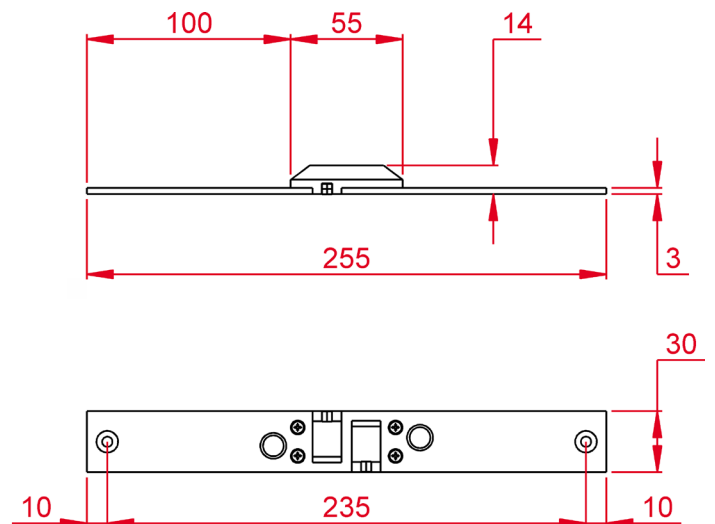
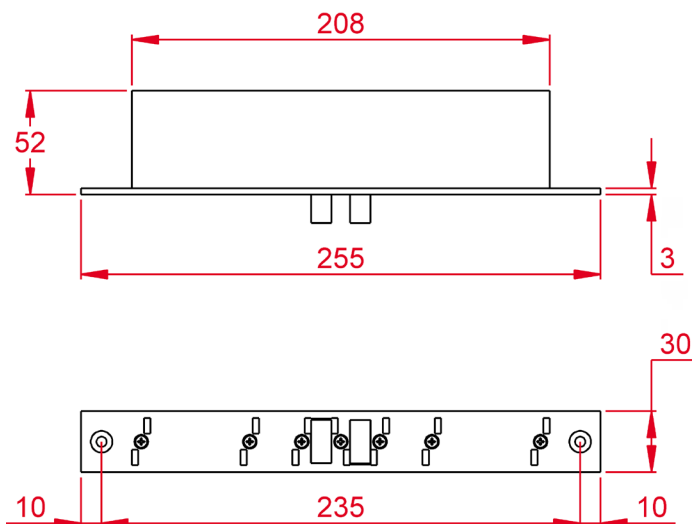

Drawings are not to scale. Dimensions are in millimetres (mm).



Contact lock.sales@theavagroup.com to be put in touch with your local representative.

www.bqtsolutions.com