



INSTALLATION AND OPERATING INSTRUCTIONS

YG80 ORCA

NOTICES



Please ensure you read all instructions!

- WARNING - Live parts inside.
- WARNING - The handling and installation of this device is recommended for a professional.
- WARNING - Use of an unsuitable power supply unit may cause product failure or injury.
- WARNING - Operation of lock while submerged may cause product failure.
- WARNING - Lock surface may become hot to touch when heater is active.



This device complies with Part 15 of the FCC Rules. Operation is subject to the following two conditions:

1. This device may not cause harmful interference.
2. This device must accept any interference received, including interference that may cause undesired operation.

Note: This equipment has been tested and found to comply with the limits for a Class B digital device, pursuant to Part 15 of the FCC Rules. These limits are designed to provide reasonable protection against harmful interference when the equipment is operated in a residential, commercial, or industrial environment. This equipment generates, uses, and can radiate radio frequency energy and, if not installed and used in accordance with the instruction manual, may cause harmful interference to radio communications. However, there is no guarantee that interference will not occur in a particular installation.

Modifications: Any modifications made to this device that are not approved by BQT Solutions (SEA) Pte. Limited may void the authority granted to the user by the FCC to operate this equipment.

Innovation, Science and Economic Development Canada ICES-003:
CAN ICES-3(B)/NMB-3(B)



This product is carrying the CE Mark in accordance with the related European Directives. Responsible for CE Marking is,

BQT Solutions (SEA) Pte. Limited
41B Neil Road, #03-01,
Singapore, 088824

The complete EU Declaration of Conformity is available at www.bqtsolutions.com



In the European Union, Norway, Iceland and Liechtenstein: This symbol on the product, or in the manual and in the warranty, and/or on its packaging indicates that this product shall not be treated as household waste. Instead it should be taken to an applicable collection point for the recycling of electrical and electronic equipment.

By ensuring this product is disposed of correctly, you will help to prevent potential negative consequences to the environment and human health, which could otherwise be caused by inappropriate handling of this product.

In Countries Outside the European Union, Norway, Iceland and Liechtenstein: If you wish to dispose of this product please contact your local authorities and ask for the correct way of disposal.

© 2019 BQT Solutions (SEA) Pte Limited. All rights reserved.

BQT Solutions (SEA) Pte Limited will not be liable for any direct, indirect, incidental or consequential loss or damage in any way related to this product. BQT Solutions (SEA) Pte Limited reserves the right to upgrade or change this product or instructions manual without prior notice. BQT Solutions (SEA) Pte Limited assumes no liability for damages incurred directly or indirectly from errors, omissions or discrepancies between the product and the manual.

The Orca is designed by BQT Solutions (SEA) Pte Limited and manufactured by BQT Solutions (NZ) Limited in New Zealand.

For more information and contact details please visit,

www.bqtsolutions.com

CONTENTS

1. DESCRIPTION.....	4
2. PRODUCT UNBOXED	4
3. DIMENSIONS	5
3.1. LOCK.....	5
3.2. STRIKE.....	5
4. PRE-INSTALLATION ASSESMENT.....	6
4.1. MECHANICAL	6
4.2. ELECTRICAL.....	6
5. INSTALLATION.....	7
5.1. MOUNTING LOCK	7
5.2. MOUNTING STRIKE.....	7
5.3. CONFIGURE AND COVER	8
6. CONFIGURATION.....	9
6.1. WIRING	9
6.2. DIP SWITCH POSITIONS.....	10
7. OPERATION.....	11
7.1. OPERATION MODES	11
7.2. FAILURE MODES	11
7.3. HEATER MODE (REQUIRES 24VDC POWER SUPPLY)	11
8. SPECIFICATIONS.....	12
9. MAINTENANCE AND INSPECTION.....	12

1. DESCRIPTION

The Orca is a low-voltage motor-driven heavy-duty lock suited for securing gates, roller doors, shipping containers, and any other large door or entryway. The Orca is designed to be weatherproof, low maintenance, and easy to install. It is supplied with a matching strike plate and can be installed externally or internally in a horizontal or vertical position. A solid 18mm diameter stainless steel bolt pin ensures the highest strength while a bolt pin extension of 30mm offers flexible installation.

Integrated electronics provide complete control over the lock and offer an array of features;

- Multi-voltage input (12-24VDC)
- Ingress protection to IP67
- Built-in heater for colder climates
- Multiple locking / unlocking attempts
- Multiple control methods
- Fail Safe / Fail Secure user selection with a single switch
- Door position monitoring
- Bolt locked and Bolt unlocked monitors
- Tamper Detection monitoring

The lock incorporates complete waterproofing to seal the lock around the bolt pin and lid, and wiring is run securely through a cable gland in the locks base.

2. PRODUCT UNBOXED



Lock (And Cable)

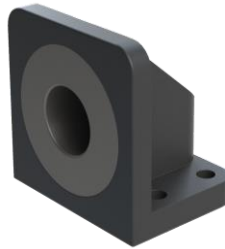

Strike



Neoprene Gasket (Optional Use)

In the box you will find the Lock, with attached 3 metre sealed cable; the Strike, with Strike Configuration Guide; and the Neoprene Gasket.

Because the Orca can be installed onto various mounting surfaces, with different requirements for fasteners depending on the surface material, **no mounting bolts are supplied**. The 3 mounting holes in the lock and 4 in the strike are 8mm holes so accept M8 size bolts (or similar fasteners).

The included 1mm thick neoprene gasket provides insulation and shock protection between the Orca and its mounting surface. By using the neoprene gasket you ensure that the heat generated when the internal heater is active (See *Section 7.3*) is not removed from the lock, this can occur when the mounting surface acts as a heat sink.

In freezing climates or where wind chill is a problem, it is recommended to consider covering the lock in an insulating material alongside use of the neoprene gasket. Very cold air temperatures or strong winds can pull heat off of the Orca faster than the heater can produce, so an insulating cover will ensure the heat is retained and allow the Orca to operate correctly and efficiently.

3. DIMENSIONS

The dimensions shown are approximate and are subject to change without prior notice.

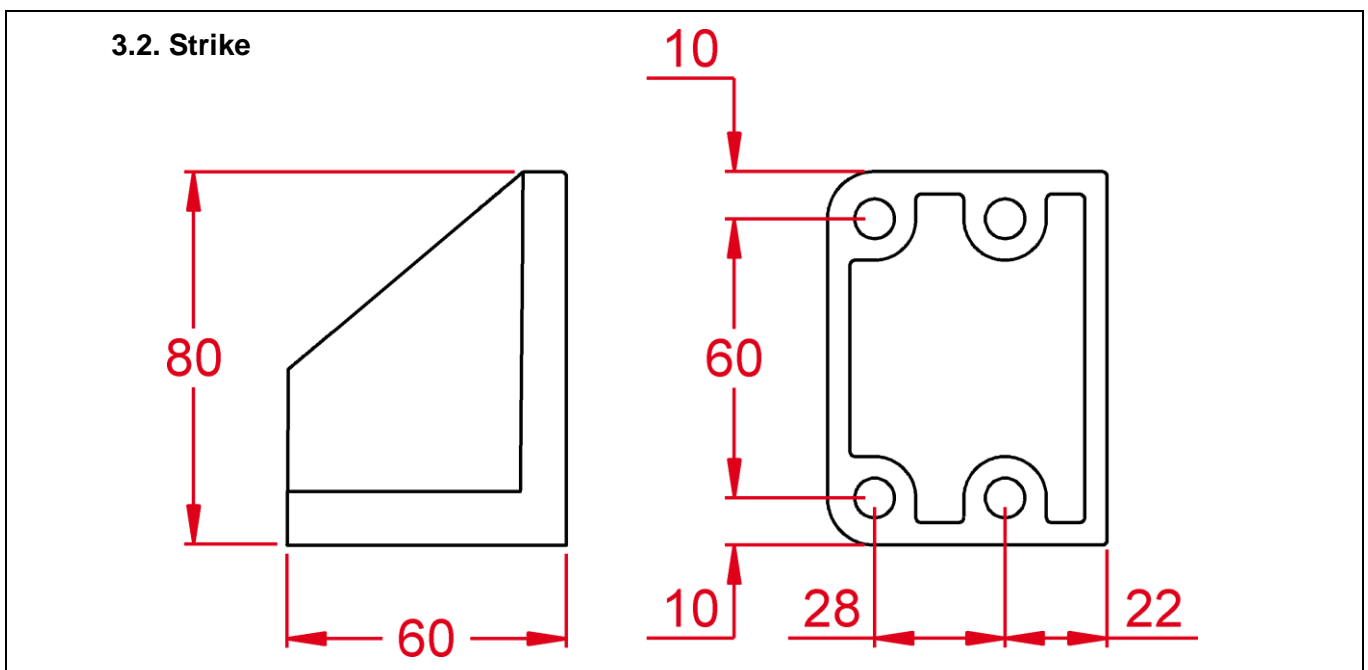
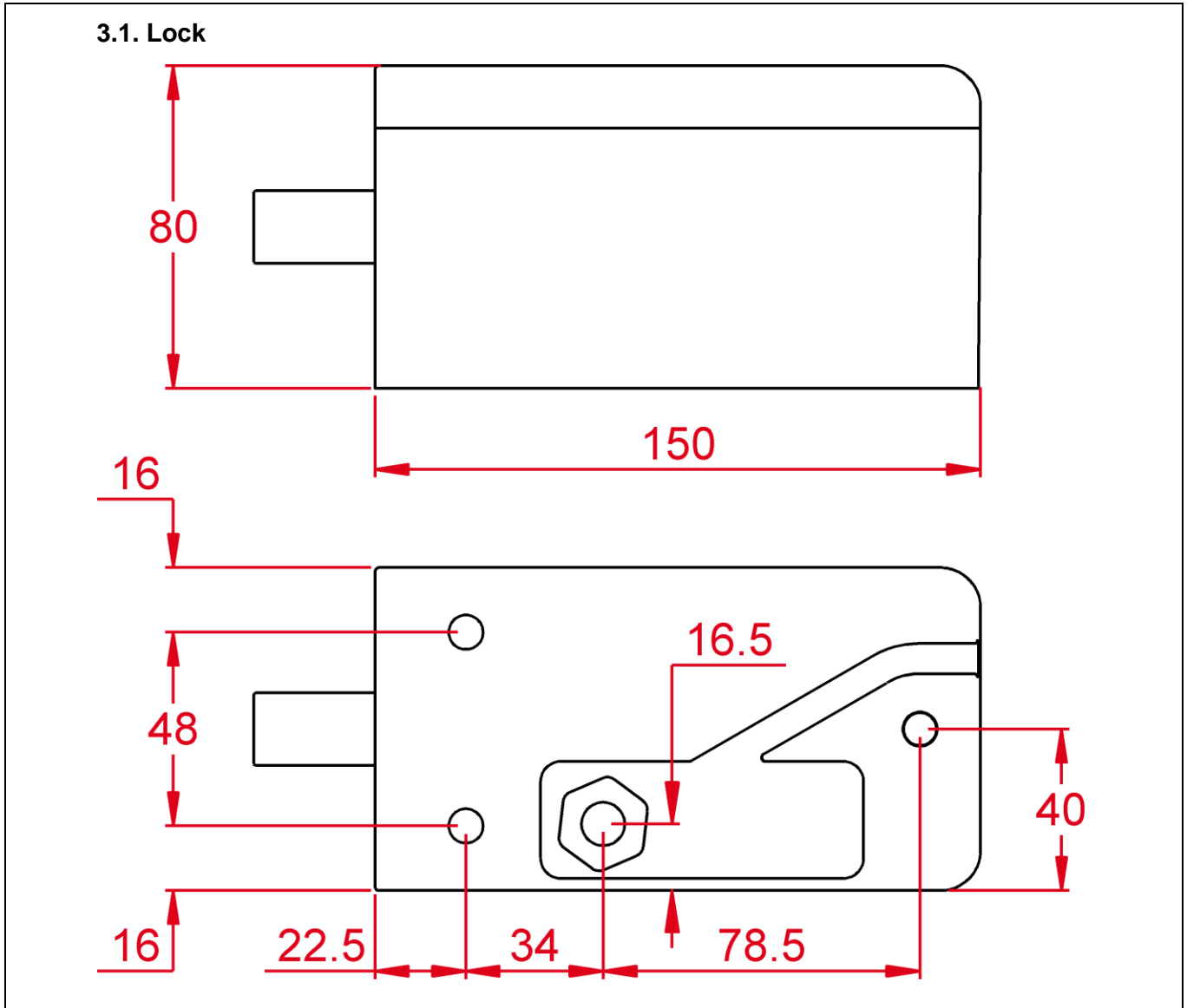

4. PRE-INSTALLATION ASSESMENT

4.1. Mechanical

Before the lock can be installed, consider its location and orientation. The Orca can be mounted horizontally or firing downwards vertically, however mounting it firing upwards vertically may deteriorate the bolt pin seal faster **and will void warranty**.

When positioning the strike, it is important to achieve a reasonable level of alignment with the bolt pin as to ensure correct locking and operation. The hole in the strike is of a larger diameter than that of the bolt pin, however installing the strike so the bolt pin goes into the hole centrally is best as it will allow for movement of the door over time. To ensure the Orca operates properly, the lock and strike must be separated by **15mm or less**.

The adjustable nature of the strike means that the supplied magnet can be inserted in the desired location for all operating conditions, meaning the strike can approach from either the right, left, top or bottom face of the lock.



Lock mounted to the ground.



Lock mounted to the door frame horizontally.



Lock mounted to the door frame vertically down.



DO NOT mount the lock vertically up.

4.2. Electrical

After the positions of the lock and strike are determined, establish where to run the cable and also decide on what feedback is required from the lock. Please refer to wiring guide in Section 6.1.

The cable is secured internally, and can either be run out of the base of the lock into the mounting surface or follow the channel in the base and be run out of the back end of the lock. If the cable is being run through the base, an additional hole is needed in the mounting surface for the cable to be pulled through.

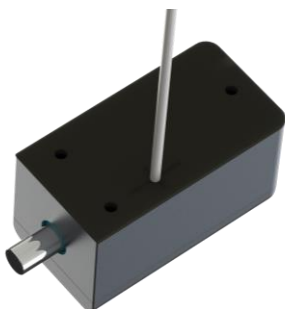

Cable being run out through the neoprene gasket

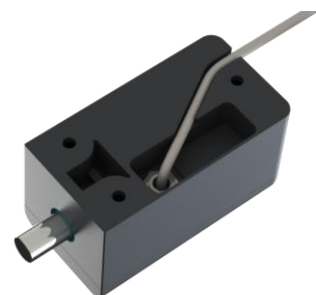

Cable being tracked out the back through the channel

5. INSTALLATION

Because this lock can be installed on many different styles of doors, a generic installation instruction is provided. Ensure that the lock component is mounted to the stationary part of the door, and the strike component is mounted to the moving part of the door. Ensure you have the required mounting fasteners for your specific installation scenario. The required number of fasteners are 7 (3 for the lock component, 4 for the strike component).

5.1. Mounting Lock

5.1.1. Drill the lock mounting holes

The mounting holes in the Orca lock component are sized for M8 fasteners.

Referring to the dimension drawings in *Section 3.1*; drill the holes at the marked location using appropriate tools, such as an M8 drill bit and power drill. If the cable is going to be run through the mounting surface, an 8mm hole can be used for the cable hole as well.

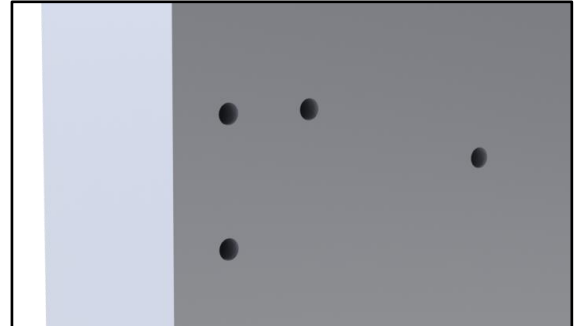

5.1.2. Prepare cable run

Before the lock can be mounted to the surface, the cable must be prepared. In the case of running the cable out the back end of the lock, track the cable along the channel. If the cable is going to be run straight out of the base of the lock, completely thread the cable through the prepared cable hole in the mounting surface. If the neoprene gasket is being used, thread the cable through the hole at the centre of the cross first.

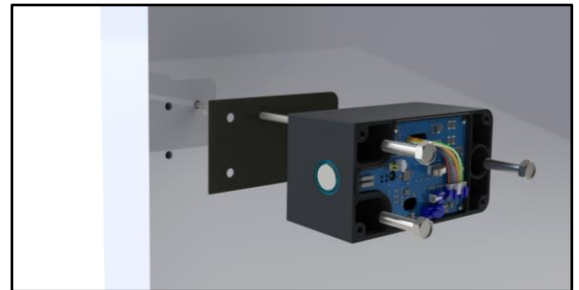

Note: Ensure the cable is not pinched or severed when mounting the lock or threading through the hole. Make sure the cable doesn't rest on any sharp edges.

5.1.3. Secure the lock in position

Once the cable has been prepared, the lid of the lock must be removed to reveal the three mounting holes; this can be done by using a 4mm hex key to remove the four screws securing the lid. Once this has been done, mount the lock in place using the appropriate fasteners for the mounting surface material.

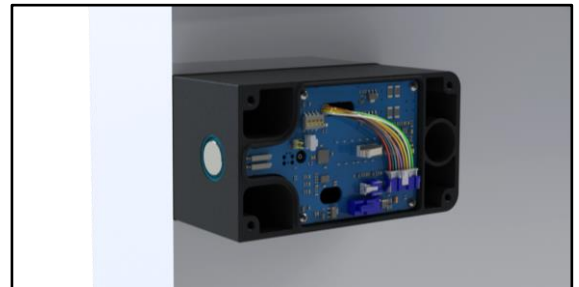

5.2. Mounting Strike

5.2.1. Drill the strike mounting holes

The mounting holes in the Orca strike are sized for M8 fasteners.

Referring to the dimension drawings in *Section 3.2*; drill the holes at the marked location using appropriate tools, such as an M8 drill bit and power drill.

Note: Ensure the gap between the lock and strike (when the door is closed) does not exceed 15mm.

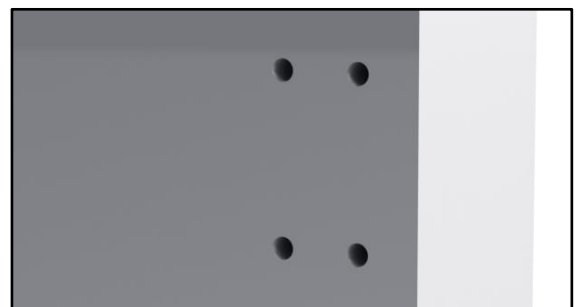

5.2.2. Strike Configuration

By default the strike is configured for use when the lock and strike are mounted on the same plane, so that the top of the strike and the top of the lid of the lock align when the door is closed. If the strike needs to be installed at 90 degrees to the lock, the strike will need to be reconfigured.

To configure the strike, hold the strike with the plastic strike ring face up and remove the M3 screw in the centre at the base of the hole using a #2 phillips screwdriver. Once removed, lift out the strike ring to reveal the magnet sitting in one of the three magnet holes. This position is determined by the location of the magnet sensor in the lock, which is above the bolt pin, near the edge of the lid.

Once you have determined this location, move the magnet to the desired location, then secure the magnet by refitting the plastic strike ring and securing with the M3 screw.

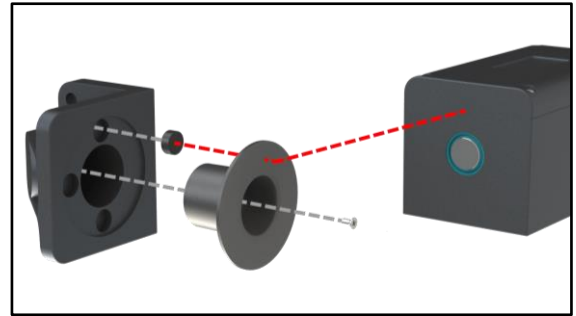

5.2.3. Secure the strike in position

Once the strike has been configured for the specific installation, mount the strike in place using the appropriate fasteners for the mounting surface material.

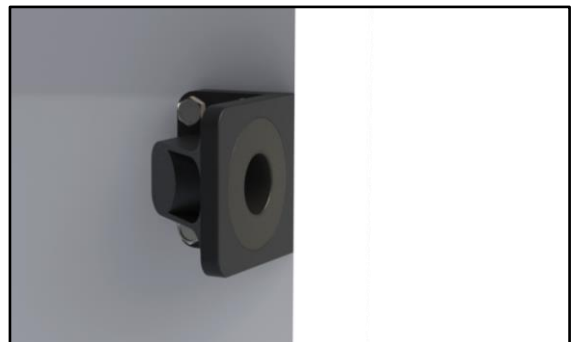

5.3. Configure and Cover

5.3.1. Configure the lock

Connect the wires on the end of the cable to the power supply, access control system, alarm system, or entry/exit devices (Refer to *Section 6.1 Wiring*).

With the lid still removed, adjust the dip switches to the desired setting using a sharp tool such as a small flat head screwdriver (Refer to *Section 6.2 Dip Switch Positions*).

When power is supplied to the lock, after the 25 second start-up time the yellow LED to the left of the dip switches should blink indicating it has powered up

When the door is in the closed position the green LED to the left of the dip switches should light up indicating that the magnet in the strike has been detected. If this does not happen please check that the door gap is less than 15mm and the magnet is in the correct position in the strike.

Note: The micro USB port is for factory use only.

5.3.2. Cover the lock

Finally screw the lid down onto the lock with a 4mm hex key. Ensure the lid is screwed down evenly and tight as otherwise the lock sealing may be compromised. Any remaining systems can now be activated, including those that take advantage of the anti-tamper monitor.

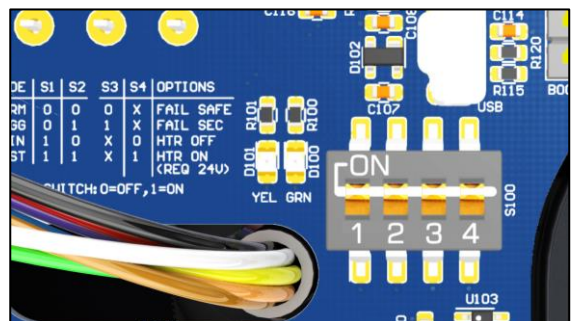

6. CONFIGURATION

6.1. Wiring

6.1.1. Wiring Overview

The wires are part of a 3 metre sealed cable out of the Orca, the wires can be routed back to the power supply and any sensors or alarm systems. In the case of requiring a longer run, the wires can be extended as appropriate to the installation. Connect the wires as per the table below, where power and control are required for the Orca to function, and all switch monitors are optional.

RED	Positive +	Positive connection to DC power supply	Power (12 – 24V)
BLACK	Negative -	Negative connection to DC power supply	
BLUE	Control 1	Switched positive control input	Control*
BROWN	Control 2	Switched positive control input (Refer to <i>Section 7.1.3</i>)	
YELLOW	Bolt Unlock Switch	Normally open contact (NO), closed when the bolt pin is retracted	
ORANGE	Bolt Lock Switch	Normally open contact (NO), closed when the bolt pin is extended	
PURPLE	Door Position Switch	Normally open contact (NO), closed when the strike is aligned with the lock	
GREEN	Tamper Detection Switch	Normally closed contact (NC), open when the lid is removed or wires cut	
WHITE	Switch Common	Common contact for all the switch monitors	

* Control 1 is required for all operating modes, however Control 2 is only required for twin wire mode.

6.1.2. Fail Safe Connection (Normal Mode)

When wiring the Orca, the positive voltage is connected to **RED**, negative is connected to **BLACK** and a switched positive voltage wire connected to **BLUE**. In Fail Safe configuration applying voltage to the **BLUE** control wire signals it to lock. The lock signal in Fail Safe configuration is active high.

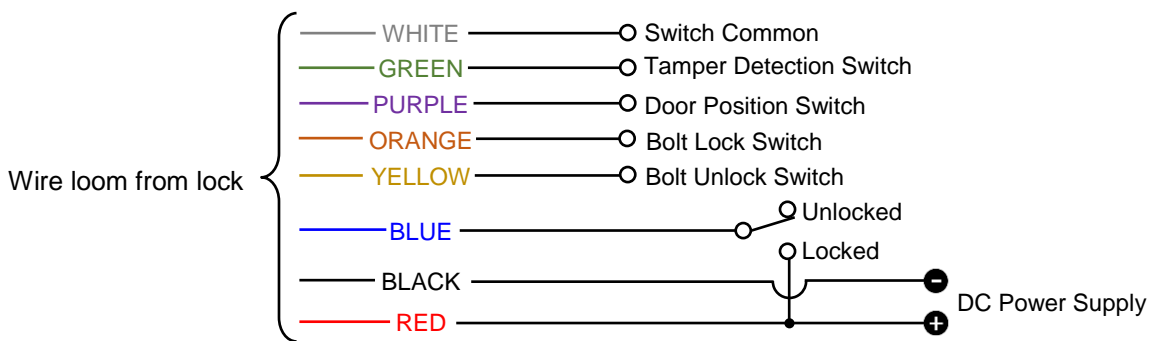

6.1.3. Fail Secure Connection (Normal Mode)

When wiring the Orca, the positive voltage is connected to **RED**, negative is connected to **BLACK** and a switched positive voltage wire connected to **BLUE**. In Fail Secure configuration applying voltage to the **BLUE** control wire signals it to unlock. The lock signal in Fail Secure configuration is active low.

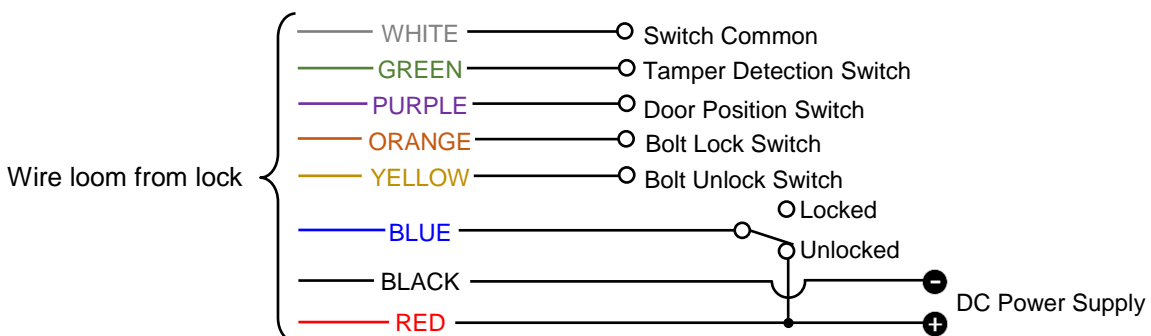

6.1.4. Toggle Mode (And Twin Wire Mode)

When wiring the Orca, the positive voltage is connected to **RED**, negative is connected to **BLACK** and a switched positive voltage wire connected to **BLUE** (and **BROWN** for Twin Wire Mode). In Toggle Mode, applying a pulse to the **BLUE** control wire toggles between lock and unlock. In Twin Wire Mode, applying a pulse to the **BLUE** control wire triggers the Orca to lock and applying a pulse to the **BROWN** control wire triggers the Orca to unlock.

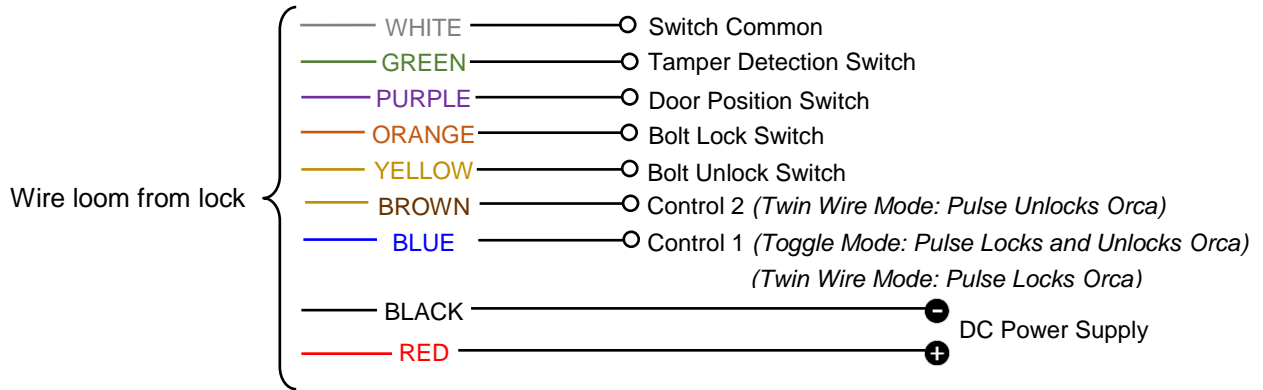

6.2. Dip Switch Positions

The operating configuration of the Orca controls how the lock will function and there are several settings available. There are four dip switches on the printed circuit board with three being used to configure the lock and the fourth for diagnostic purposes. The dip switches are located on the top of the printed circuit board (pictured below) and can be set as per the following table.



DIP SWITCH #	SETTING	DESCRIPTION
1	Operation Modes	Set how the control line/s lock or unlock the Orca. (Refer to <i>Section 7.1</i>)
2		
3	Failure Modes	Set whether the Orca will lock or unlock on failure. (Refer to <i>Section 7.2</i>)
4	Heater Mode	Set whether the heater will activate at low temperatures. Use this setting when the ambient temperature can drop below 0°C (Refer to <i>Section 7.3</i>)

1	2	
OFF	OFF	Normal Mode Operation
OFF	ON	Toggle Mode Operation
ON	OFF	Twin Wire Mode Operation
ON	ON	Diagnostic Mode Operation

3	
OFF	Fail Safe Mode, the Orca will unlock on failure
ON	Fail Secure Mode, the Orca will lock on failure

4	
OFF	Heater Off
ON	Heater On (Requires 24VDC to be supplied)
TOGGLE	Next Diagnostic Test (Diagnostic Mode Only)

7. OPERATION

7.1. Operation Modes

7.1.1. Normal Mode

The **BLUE** 'Control 1' connection is used to lock and unlock the Orca by either being connected to the supply voltage or being disconnected. The function of normal mode depends on the current failure mode setting.

When in **Fail Safe** mode, if power is applied to the **BLUE** 'Control 1' connection, and the Orca detects the door is closed, the bolt will engage and lock the door. When power is removed, the bolt will disengage and unlock the door. When in **Fail Secure** mode, if power is removed from the **BLUE** 'Control 1' connection, and the Orca detects the door is closed, the bolt will engage and lock the door. When power is applied, the bolt will disengage and unlock the door.

7.1.2. Toggle Mode

The **BLUE** 'Control 1' connection is used to lock and unlock the Orca by applying a pulse of the supply voltage to toggle the state of the lock. This function does not depend on the failure mode setting.

If a short pulse is applied to the **BLUE** 'Control 1' connection the bolt will disengage and unlock the door. When a second pulse is applied to the **BLUE** 'Control 1' connection, and the Orca detects the door is closed, the bolt will engage and lock the door.

7.1.3. Twin Wire Mode

The **BLUE** 'Control 1' connection is used to lock the Orca, and the **BROWN** 'Control 2' connection is used to unlock the Orca, by applying a pulse of the supply voltage. This function does not depend on the failure mode setting.

If a short pulse is applied to the **BROWN** 'Control 2' connection the bolt will disengage and unlock the door. When a pulse is then applied to the **BLUE** 'Control 1' connection, and the Orca detects the door is closed, the bolt will engage and lock the door.

7.1.4. Diagnostic Mode

There are six tests which can be cycled through by toggling the position of the fourth dip switch on or off. The yellow LED will blink based on what test number you are on. Once testing has been completed, ensure all four of the dip switches have been returned to their original operating position.

TEST	NAME	DESCRIPTION
1	Cycle Count	The green LED lights up if the cycle count is below 300,000 cycles
2	Motor Health	After 3 test cycles, if the LED goes solid green the motor is in good health.
3	Power Supply	After 10 seconds, if the LED goes solid green the power supply is probably suitable.
4	Control 1	The green LED lights up whenever the Control 1 input is active.
5	Control 2	The green LED lights up whenever the Control 2 input is active.
6	Hall Sensor	The green LED lights up whenever the strike magnet is detected.

7.2. Failure Modes

7.2.1. Fail Safe Mode

In the event of power failure, when the door is closed and the Orca is in the locked state, the bolt pin will disengage from the strike. This ensures safe passage in emergency situations, as well as access when power is unavailable.

7.2.2. Fail Secure Mode

In the event of power failure, when the door is closed and the Orca is in the locked state, the bolt will stay engaged with the strike. If the door is open and the Orca cannot detect the strike, the bolt will not engage until power returns. This ensures that a lock will not disengage during power failure, keeping the access secured.

7.3. Heater Mode (Requires 24VDC Power Supply)

The heater mode allows the Orca to be used in colder climates, where the bolt pin can become iced over. When the heater mode is enabled, the Orca will automatically activate the heater to ensure the lock is operating above freezing conditions. The heater will self-regulate and only be active when it is needed to conserve energy. Refer to *Section 2* for information about the use of the neoprene gasket for added benefits in colder climates.

8. SPECIFICATIONS

MATERIALS				
Bolt Pin	Stainless Steel (SS304), ø18mm, 30mm extension, ø28mm receiver			
Lock Body	Aluminium (A383), 150mm x 80mm x 80mm			
Strike Body	Aluminium (A383), 60mm x 80mm x 80mm			
MECHANICAL				
Cycle Life	300,000 normal operations			
Maximum Strike Gap	15mm			
Static Strength	50,000 newtons (5,000Kg)			
Dynamic Strength	200 joules (factory tested according to the UL 1034 standard)			
ELECTRICAL				
Voltage at Lock	12 – 24VDC ±15%			
Auto Relock	Will attempt to lock or unlock 3 times if obstructed during operation.			
Initial Power Up Time	25 seconds, only after power has been removed for an extended period.			
Current Usage	Standby Current	40mA@12V	30mA@24V	1.6A@24V with heater on
	Maximum Current	1.0A@12V	0.5A@24V	2.0A@24V with heater on
Monitor Switches	24VDC, 0.25A			
CERTIFICATIONS				
Environment	IP67 Rating – <i>Suitable for indoor and outdoor use</i>			
	Cold, -35°C for 2 Hours		EN 60068-2-1:2007	
	Dry Heat, +70°C for 2 Hours		EN 60068-2-2:2007	
	Corrosion, 240 Hours Salt Spray		EN 1670:2007, Grade 4	
FCC	Title 47, Part 15, Subparts A & B – Class B Device			
ISED (IC)	ICES-003 – Class B Device			
CE	EMC 2014/30/EU		EN 61000-6-1:2017	
			EN 61000-6-3:2007+A1:2011	
	RoHS 2011/65/EU		RoHS 2 Compliant	

9. MAINTENANCE AND INSPECTION

The Orca has been lubricated at assembly and applying any other type of lubricant may void the warranty. With the lid removed it is important to take care when selecting the configuration or interacting with the printed circuit board. To keep the Orca working effectively, ensure the strike hole and bolt pin are clear of debris at all times. This lock contains components that are subject to wear based on usage, doorway operation and installation; all such factors are beyond the control and measurement of the manufacturer. The lock may be vulnerable and subject to failure as a consequence of wear and as its components near the end of the period of normal usage.

It is the responsibility of the owner/end-user to:

- a) Ensure that the lock is installed in accordance with the instructions set out in these guidelines.
- b) Determine the suitability of this lock for the application intended and in particular when using this lock in critical applications such as on high security, safety, or emergency exit doors.
- c) Regularly inspect this lock in order to assess signs of wear and tear, and determine if the operation still conforms to the instructions set out in these guidelines.
- d) Regularly inspect the lock and evaluate cycle life.
- e) Determine when this lock should be replaced.