

Warranty

Unless specified otherwise, the Company warrants to the Customer that 'BQT Solutions Branded Products' (excluding third party products and software) are covered by a return to base warranty on defects in materials and workmanship affecting normal use for a period of the Warranty offered under the Standard Terms and Conditions of Sale from BQT invoice date ('Standard Warranty')

This standard warranty does not cover damage, fault, failure or malfunction due to external causes including; accident, misuse, problems with electrical power, servicing not authorised by the Company, usage and/or storage and/or installation not in accordance with Product instructions, failure to perform required preventative maintenance, normal wear and tear, act of God, fire, flood, war, any violent or similar occurrence; any attempt by any person other than Company personnel or any person authorised by the Company to repair or support the Products and problems caused by use of parts and components not supplied by the Company. The standard warranty does not cover any items that are in one or more of the following categories: software; external devices; accessories or parts added to the product after the product has been shipped from BQT Solutions.

During the warranty, period beginning on the invoice date, the Company will repair or replace faulty products (at its absolute discretion) returned to its' factory. The Customer must prepay shipping and transportation costs and insure the shipment or accept the risk of loss or damage during such transportation.

The Customer shall be solely responsible for determining suitability for use and the Company will, in no event, be liable in this respect. This standard warranty is given in place of all warranties, conditions, terms, undertakings and obligations implied by statute, common law, trade usage, and course of dealing or otherwise including warranties or conditions of merchantability, fitness for purpose, satisfactory quality and / or compliance with description, all of which are hereby excluded to the fullest extent permitted by law.

Wiring diagram

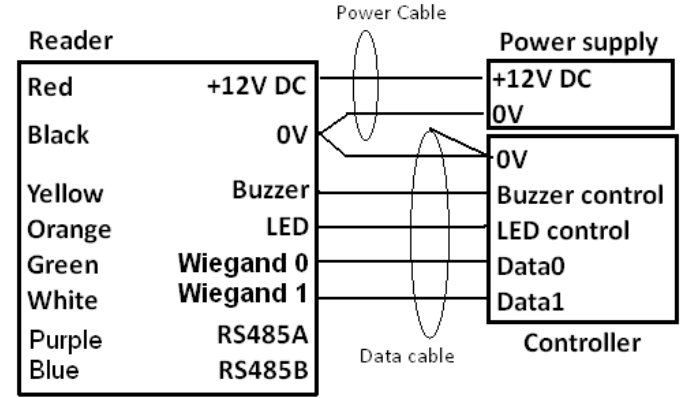

Note:

- A shielded cable is recommended to be used. The shield is connected to controller 0V reference
- Maximum wiegand data cable length: 150 meters (500 feet)
- Buzzer and LED are low activated.
- RS485 lines are only for optional use.
- Terminate or insulate all un-used wires

Regulatory Information

C-Tick: This device is C-Tick complied.

CE: The device has passed all relevant tests and obtained CE approval.

FCC: This device complies with Part 15 of the FCC Rules. Operation is subject to the following two conditions: 1) this device may not cause interference and 2) this device must accept any interference, including interference that may cause undesired operation of the device.

Warning: This equipment has been tested and found to comply with the limits for a Class B digital device, pursuant to part 15 of the FCC rules. These limits are designed to provide reasonable protection against harmful interference in a residential installation. This equipment generates uses and can radiate radio frequency energy and, if not installed and used in accordance with the instructions, may cause harmful interference to radio communications. However, there is no guarantee that interference will not occur in a particular installation. If this equipment does cause harmful interference to radio or television reception, which can be determined by turning the equipment off and on, the user is encouraged to try to correct the interference by one or more of the following measures:

- Reorient or relocate the receiving antenna.
- Increase the separation between the equipment and receiver.
- Connect the equipment into an outlet on a circuit different from that to which the receiver is connected.
- Consult the dealer or an experienced radio/TV technician for help.

Any changes or modifications not expressly approved by BQT Solutions could void the user's authority to operate this equipment.

Specifications

Output protocols	Wiegand 26-199bit, RS485 or custom configuration (Model dependent)
Power requirement	7-18V DC
Current consumption	38mA (Avg) 80mA (Peak)
Read range	20-40mm (0.8" -1.6") at 12V DC depends on the type of card used
Operating temperature	-25°C to +65°C (-13°F to 149°F)
Relative humidity	90% max, operating non-condensing
Reader dimensions	3mm flush face (BT825) 110mm(L) x 110mm(W) x 23mm(D) (4.33"x4.33"x0.91") AU Perplex plate (BT835) 116mm(L) x 84mm(W) x 26mm(D) (4.57"x3.31"x1.02") UK Perplex plate (BT835) 116mm(L) x 80mm(W) x 26mm(D) (4.57"x3.15"x1.02") 6mm Perplex plate (BT835) 150mm(L) x 150mm(W) x 26mm(D) (5.91"x5.91"x1.02")
Status LED	Green & Red
Audible tone	Internal and external buzzer control
Colour finish	Charcoal
IP rating	IP65

Information obtained in this document is subject to change without notice.

For further technical information, visit our website at www.bqtsolutions.com or email techsupport@bqtsolutions.com.

Alternatively contact us at one of our global locations

AUSTRALIA & PACIFIC

BQT Solutions (Australia) Pty Limited
Unit 29, 1 Talavera Road
North Ryde, NSW 2113, Australia
Phone: +61 (0)2 8817 2800
Fax: +61 (0)2 8817 2811
Email: sales@bqtsolutions.com

EUROPE AND MIDDLE EAST

BQT Solutions (UK) Limited
Regal House, 70 London Road
Twickenham, TW1 3QS
United Kingdom
Phone: +44 (0)20 8622 4428
Fax: +44 (0)20 8622 4401
Email: salesuk@bqtsolutions.com

GREATER ASIA

BQT Solutions Singapore Office
61 Tras Strass Street
#02-01
Singapore 079000
Phone: +65 6220 7970
Fax: +65 6220 7656
Email: salesasia@bqtsolutions.com



BT825/BT835

INSTALLATION GUIDE

Version4.3



smartersecuritytoday

Installation

Wire connection

Note:

Power to the unit is provided from the listed control unit or from a separately UL listed 12V DC power-limited, access control power source. DO NOT supply power during installation.

Wiring methods shall be in accordance with the Electrical wiring regulation in your country / region.

Check your circuit diagram for the colour coding of the circuit wiring. The reader can be damaged beyond repair if the wiring is connected incorrectly. This will void the warranty.

1. Connect the 0V wire to the power 0V line;
Note: The 0V line of all power supplies must be connected to a common 0V reference point.
 2. Connect the Wiegand data wires;
 3. Connect the Buzzer and LED wires;
 4. Connect 12V DC wire;
 5. Place reader on the mounting box (Make sure the wires are not crushed. This will void the warranty if damage occurs)
 6. Insert and hand tighten the screws;
 7. Check that the reader is level before tightening the screws;
- Note:** Excessive tightening of screws may deform the casing, resulting in a damaged unit. This will void the warranty.
8. Turn on the 12V DC power to power up reader.
 9. Allow 5 – 10 seconds for reader to finish initialization (depends on the application). Make sure reader is functioning correctly according to the application specification.

External Use

- Make sure the wire bundle to the reader has an IP rating of at least IP65

Handling

- Handle the reader with care. DO NOT damage or drop unit before installation. This will void the warranty.
- If the case is damaged, the reader may not be to the specified IP rating. Replace the reader if the case is damaged.

Maintenance

- Once installed the reader requires no maintenance.

Troubleshooting

Problem	Troubleshooting steps
Power on reader – reader does not start up	<ol style="list-style-type: none"> 1. Check connections 2. Check the voltage at the reader 3. Check the current capability of the power supply
Power on reader – reader keeps beeping	<ol style="list-style-type: none"> 1. Check buzzer line 2. Check the voltage at the reader 3. Check the current capability of the power supply
Power on reader – LED stays green	<ol style="list-style-type: none"> 1. Check LED line
Present a card to reader – a beep is heard but reader does not output any data	<ol style="list-style-type: none"> 1. Check whether the card has data encoded 2. Check the wiegand connection to controller 3. Check the voltage level on wiegand data lines
Present a card to reader – no response from reader	<ol style="list-style-type: none"> 1. Try a known working card 2. Check if the reader requires to be configured with a configuration card

If the problem still persists, please contact your distributor for technical support.

Reader Dimensions

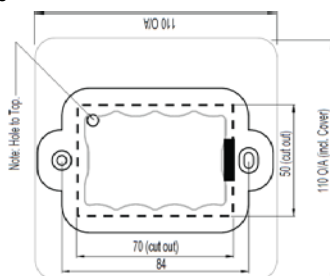

BT825 (3mm flush face). Compatible with AU/US single gang box

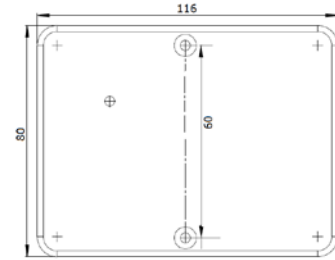

BT835 (UK Size Plate). Compatible with UK single gang box

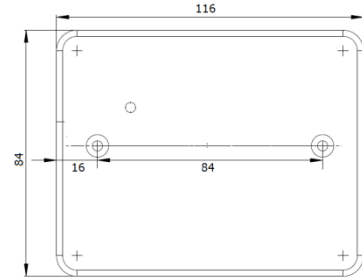

BT835 (AU Size Plate). Compatible with AU/US single gang box

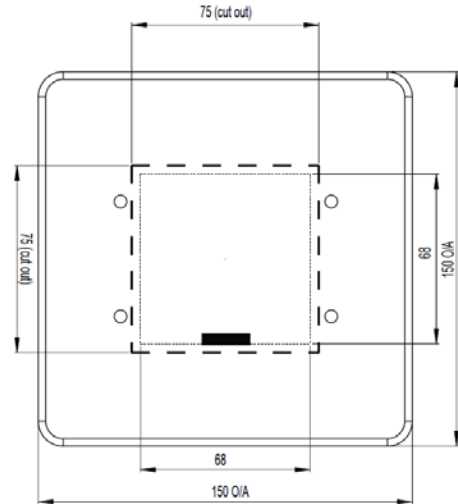

BT835 AU/D Model (6mm Perplex plate), Custom mounting holes

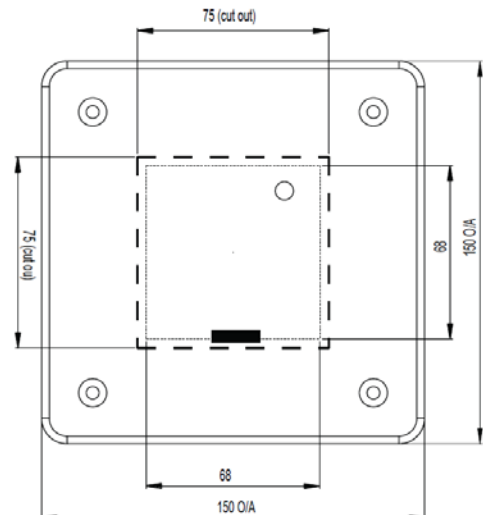

BT835 UN Model (6mm Perplex plate), Custom mounting holes