

NOT TO SCALE

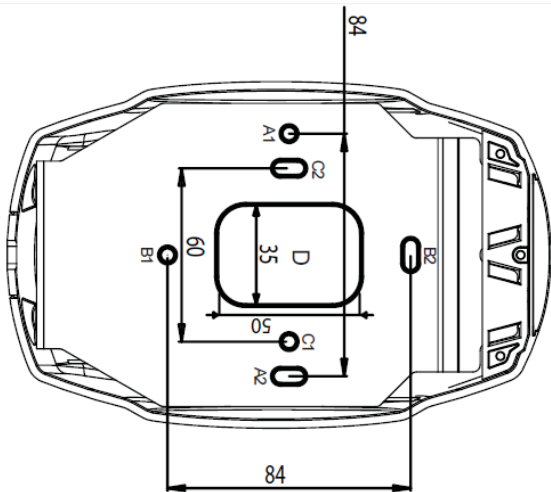

Dimensions in mm

For hole sets A, B, & C - Fasten through hole "1" first and use hole 2 to fine-tune orientation of reader.

D - Cable Outlet for "Through Wall" Mounting.

A1, A2 - US/Aus. Back Box, Horizontal Mount  
 B1, B2 - US/Aus. Back Box, Vertical Mount  
 C1, C2 - UK Back Box

For all BioX & XK Series Readers  
 Use the Mounting bracket as a guide for drilling holes -  
 Template is not to scale. Choose holes to drill according to  
 the following:

### Mounting Hole Dimensions

### Wiring diagram

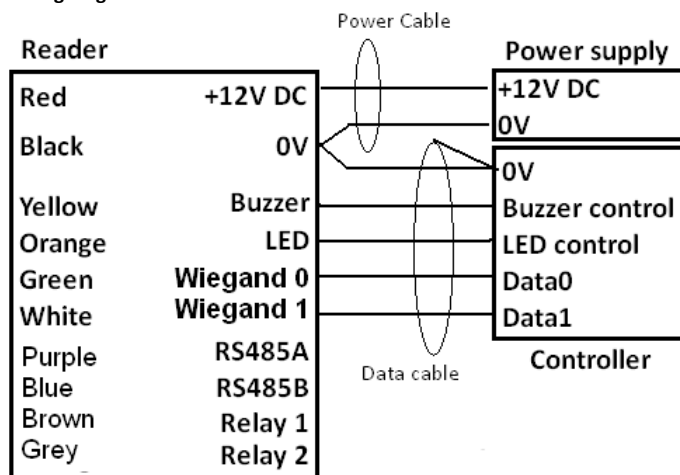

#### Note:

- A shielded cable is recommended to be used. The shield is connected to controller 0V reference
- Maximum wiegand data cable length: 150 meters (500 feet)
- Buzzer and LED are low activated.
- RS485 and Relay are only for optional use. Specific setting is required to enable these functions.
- Terminate or insulate all un-used wires

#### Regulatory Information

C-Tick: This device is C-Tick complied.

CE: The device has passed all relevant tests and obtained CE approval.

FCC: This device complies with Part 15 of the FCC Rules. Operation is subject to the following two conditions: 1) this device may not cause harmful interference and 2) this device must accept any interference received, including interference that may cause undesired operation of the device.

Warning: This equipment has been tested and found to comply with the limits for a Class B digital device, pursuant to part 15 of the FCC rules. These limits are designed to provide reasonable protection against harmful interference in a residential installation. This equipment generates uses and can radiate radio frequency energy and, if not installed and used in accordance with the instructions, may cause harmful interference to radio communications. However, there is no guarantee that interference will not occur in a particular installation. If this equipment does cause harmful interference to radio or television reception, which can be determined by turning the equipment off and on, the user is encouraged to try to correct the interference by one or more of the following measures:

- Reorient or relocate the receiving antenna.
- Increase the separation between the equipment and receiver.
- Connect the equipment into an outlet on a circuit different from that to which the receiver is connected.
- Consult the dealer or an experienced radio/TV technician for help.

Any changes or modifications not expressly approved by BQT Solutions could void the user's authority to operate this equipment.

### Specifications

Output protocols	Wiegand or RS485 (Model dependent)	
Model	BTBIOX/DFBIOX BIOMIP2X/BIOMIP3X	BTBIOXK/DFBIOXK BIOMIP2XK/BIOMIP3XK
Power requirement	7 - 18V DC (Nominal operating voltage 12V DC)	
Current consumption (12V DC)	48mA (Idle) 173mA (Peak)	48mA (Idle) 257mA (Peak)
Relay Rating	80mA	
Read range	20-40mm (0.8"-1.6") at 12V DC depends on the type of card used	
Operating temperature	-10°C to +50°C (14°F to 122°F)	
Relative humidity	90% max, operating non-condensing	
Reader dimensions	190mm(L) x 119mm(W) x 58mm(D) (7.5" x 4.7" x 2.3")	
Status LED	Green & Red Bi-colour, Blue, Orange	
Audible tone	Internal and external buzzer control	
Keypad (XK only)	3 x 4 Keypad and 4 Function keys, illuminated	
Colour finish	Charcoal Only	Charcoal/Ivory
IP rating	IP65	

Information obtained in this document is subject to change without notice.

For further technical information, visit our website at [www.bqtsolutions.com](http://www.bqtsolutions.com) or email [techsupport@bqtsolutions.com](mailto:techsupport@bqtsolutions.com).

Alternatively contact us at one of our global locations

#### AUSTRALIA & PACIFIC

BQT Solutions (Australia) Pty Limited  
 Unit 29, 1 Talavera Road  
 North Ryde, NSW 2113, Australia  
 Phone: +61 (0)2 8817 2800  
 Fax: +61 (0)2 8817 2811  
 Email: [sales@bqtsolutions.com](mailto:sales@bqtsolutions.com)

#### EUROPE AND MIDDLE EAST

BQT Solutions (UK) Limited  
 Regus, Castle Court, 41 London Road  
 Reigate, RH2 9RJ  
 United Kingdom  
 Phone: +44 (0)17 3773 5071  
 Fax: +44 (0)17 3773 5072  
 Email: [salesuk@bqtsolutions.com](mailto:salesuk@bqtsolutions.com)

#### GREATER ASIA

BQT Solutions Singapore Office  
 61 Tras Strass Street  
 #02-01  
 Singapore 079000  
 Phone: +65 6220 7970  
 Fax: +65 6220 7656  
 Email: [salesasia@bqtsolutions.com](mailto:salesasia@bqtsolutions.com)



BioX Series



BioXK Series

smartersecuritytoday

# BioX/XK Series

## INSTALLATION GUIDE

Version 3.2



## Installation

This reader may be mounted in either 'Through Wall' or 'On Wall' configurations as follows:

### Through Wall:

All wires exit at the back of reader, and are collected in a 'back box' (not included) that is mounted behind the reader - either inside the wall or on the far side. Do not remove break-away cover at bottom of reader if mounting through wall. Choose holes to suit your preferred back box type and orientation (refer to Hole Dimensions).

### On Wall:

Break-away cover at bottom of reader is removed, and wires exit bottom of reader via a 20mm conduit fitting (not included). A back box is not used in this configuration, so choose hole locations that are secure and accessible. It is not necessary to drill hole 'D' if mounting 'On Wall.'

1. Review Hole Dimension diagram (overleaf).

2. Select and Drill appropriate holes - the Mounting Bracket may be used as a template.

**NOTE:** Be careful not to drill through any cables

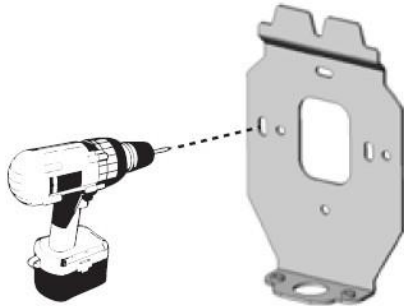

## Wire connection

### Note:

Power to the unit is provided from the listed control unit or from a separately UL listed 12V DC power-limited, access control power source. DO NOT supply power during installation.

Wiring methods shall be in accordance with the Electrical wiring regulation in your country / region.

Check your circuit diagram for the colour coding of the circuit wiring. The reader can be damaged beyond repair if the wiring is connected incorrectly. This will void the warranty.

1. Connect the 0V wire to the power 0V line;

**Note:** The 0V line of all power supplies must be connected to a common 0V reference point.

2. Connect the Wiegand data or RS485 wires;

3. Connect the Buzzer and LED wires;

4. Connect 12V DC wire;

5. Placing reader

1. Insert Screw (not included) into smaller, circular hole.

2. Insert Screw (not included) into larger, slotted hole, but do not fully tighten. Ensure that edges of Wall Bracket are vertical, then tighten screw.

3. Hook reader onto Wall Bracket.

4. Join Reader to Wall Bracket with Base Screws (included).

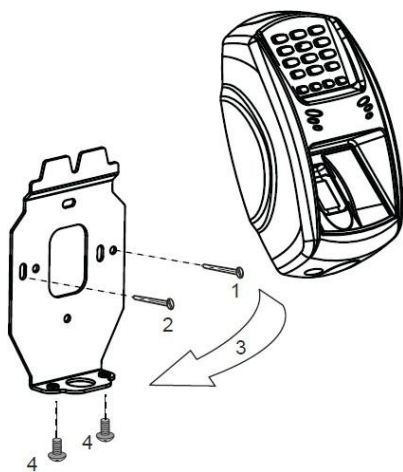

6. Turn on the 12V DC power to power up reader.

7. Allow 10 – 15 seconds for reader to finish initialization (depends on the application). Make sure reader is functioning correctly according to the application specification.

8. Reader's antenna is located at the 6 LED lights area at the front of the reader body.

## External Use

• Make sure the wire bundle to the reader has an IP rating of at least IP65

## Handling

- Handle the reader with care. DO NOT damage or drop unit before installation. This will void the warranty.
- If the case is damaged, the reader may not be to the specified IP rating. Replace the reader if the case is damaged.

## Maintenance

- Once installed the reader requires no maintenance.
- Occasionally Use a dry cloth with gentle pressure and movement to clean the sensor surface from time to time. Do not use any abrasive materials or commercial cleaning, alcohol, acid or caustic solutions at any time, you may damage the unit and void your warranty.

## Troubleshooting

Problem	Troubleshooting steps
Power on reader – reader does not start up	1. Check connections 2. Check the voltage at the reader 3. Check the current capability of the power supply
Power on reader – reader keeps beeping	1. Check buzzer line 2. Check the voltage at the reader 3. Check the current capability of the power supply
Power on reader – LED stays green	1. Check LED line
Present a card to reader – a beep is heard but reader does not output any data	1. Check whether the card has data encoded 2. Check the wiegand connection to controller 3. Check the voltage level on wiegand data lines
Present a card to reader – no response from reader	1. Try a known working card 2. Check if the reader requires to be configured with a configuration card

If the problem still persists, please contact your distributor for technical support.

## Warranty

Unless specified otherwise, the Company warrants to the Customer that ' BQT Solutions Branded Products' (excluding third party products and software) are covered by a return to base warranty on defects in materials and workmanship affecting normal use for a period of the Warranty offered under the Standard Terms and Conditions of Sale from BQT invoice date ('Standard Warranty')

This standard warranty does not cover damage, fault, failure or malfunction due to external causes including; accident, misuse, problems with electrical power, servicing not authorised by the Company, usage and/or storage and/or installation not in accordance with Product instructions, failure to perform required preventative maintenance, normal wear and tear, act of God, fire, flood, war, any violent or similar occurrence; any attempt by any person other than Company personnel or any person authorised by the Company to repair or support the Products and problems caused by use of parts and components not supplied by the Company. The standard warranty does not cover any items that are in one or more of the following categories: software; external devices; accessories or parts added to the product after the product has been shipped from BQT Solutions.

During the warranty, period beginning on the invoice date, the Company will repair or replace faulty products (at its absolute discretion) returned to its' factory. The Customer must prepay shipping and transportation costs and insure the shipment or accept the risk of loss or damage during such transportation.

The Customer shall be solely responsible for determining suitability for use and the Company will, in no event, be liable in this respect. This standard warranty is given in place of all warranties, conditions, terms, undertakings and obligations implied by statute, common law, trade usage, and course of dealing or otherwise including warranties or conditions of merchantability, fitness for purpose, satisfactory quality and / or compliance with description, all of which are hereby excluded to the fullest extent permitted by law.