

# BIOMETRIC READERS

## Bio XK

### FINGERPRINT



#### Product Overview

The BioXK is a three-factor fingerprint biometric and MIFARE® smart card reader able to integrate seamlessly with existing systems. It can be configured as 'template and pin on card' or for complete control, managed with miPASS Access software. The BioXK is available in a range of secure options right up to Military grade technology and encryption and provides a flexible solution through customisation to suit all access control requirements. Engineered to offer ultimate security by combining leading-edge fingerprint scanning with secure encryption, the BioXK offers biometric access control to high-security areas.

#### Why BQT Solutions

BQT Solutions is a specialist in the development, manufacture and supply of high quality, high security card and biometric readers, electromechanical locks and related electronic security products. Providing high security solutions to verticals such as Airports, Hospitals, Prisons and Government for over 35 years.

*Innovating today for a more secure tomorrow*

#### Product Benefits

##### Benefit One

Three factor authentication for a higher level of access control security, using a keypad for a pin, a fingerprint scanner for biometric security alongside the MIFARE® Classic & DESFire® 13.56MHz readers and smart cards.

##### Benefit Two

Offering pre-configured and customised operations, the BioXK can be set up to accept your custom key, data formats and is designed to work with your pre-existing security configurations.

##### Benefit Three

The BioXK offers installation flexibility and integration with many existing access panels and can be customised to suit a proprietary system. When you receive your reader, all you will have to do is connect them in to secure your site with your existing access control system.

---

## PRODUCT FEATURES

### Compatibility

---

Available with MIFARE Classic and DESFire proximity cards for contactless smart card technology. The BQT Solution's suite of MIFARE Classic & DESFire® readers and smart cards, opens the gateway to multiple security applications, including access control, biometric authentication, IT security, e-purse, e-vending, time, and attendance to ensure your security needs are being met.

### Robust Design

---

The solid nature of the BioXK ensures it can withstand tampering and maintain integrity during a security threat or incident. It is designed to withstand common reader threats, including excessive force from a hammer or heavy tool, and will continue to operate and secure access even after being damaged.

### Secure Encryption

---

Working with your current system, the BioXK offers flexible access control, with the option to use Wiegand, OSDP or Encrypted RS485 access data output. The BioXK additional benefits of being cost-effective and easy to wire and deploy across your sites where different levels of encryption are needed for secure access control.

### Encrypted Template

---

Encrypted securely onto the card, fingerprints are stored as an encrypted template file, unable to be duplicated or used anywhere else, and is impossible to convert back into a fingerprint image. The file is used to confirm the user's identity but is never stored on the reader or any backend database. Instead, the data is only stored on the user's access card, meaning only the user has physical control over the template.

BQT Solutions understands there are many concerns around the privacy and security of a user's biological data. It is of utmost importance to BQT to ensure data is not compromised. Therefore, BQT Solutions does not collect any data, only transforming fingerprints templates into secure encrypted data files for the sole purpose of access control with assigned BQT readers.

---

## PRODUCT APPLICATIONS

Highly security conscious sites requiring additional layers of authentication to ensure only the correct people are granted access. Often used in Military or sensitive commercial locations, the BioXK is the preferred solution where true access control is needed.



## SPECIFICATIONS

- **Voltage at Reader**  
8VDC to 16VDC
- **Current Usage**  
Average: 280mA  
Peak: 380mA
- **Card Read Range**  
20mm to 40mm (0.8" to 1.6")
- **Operating Temperature**  
-10°C to +50°C (+14°F to +122°F)
- **Relative Humidity (% max)**  
90%, operating non condensing
- **Reader Dimensions**  
190mm (7.48") X 120mm (4.72")  
X 60mm (2.36")
- **Materials**  
Reader / Shroud Body: ABS  
Plastic  
Colour Finish: Charcoal Mounting  
Bracket: Stainless Steel
- **Feedback**  
Green/Red/Blue LED, with  
external control  
Buzzer, with external control
- **Sensor**  
Optical fingerprint sensor
- **Keypad**  
16 button illuminated, PIN on  
Card (PoC), 8-bit COTAG, or  
custom
- **Credential Options**  
ISO14443A, MIFARE Classic®  
1K/4K, MIFARE Plus® X 2K/4K,  
MIFARE® DESFire® EV1 4K/8K,  
MIFARE® DESFire® EV2 4K/8K,  
MIFARE® DESFire® EV3 4K/8K
- **Compliance and Certification**  
FCC, CE, UKCA, RCM, RoHS,  
IP65
- **Reader Variants**  
BioXK-1 – CSN Reader  
BioXK-2 – miPASS2 Reader  
BioXK-3 – Custom MIFARE  
Classic Reader  
BioXK-4 – miPASS3 Reader  
BioXK-5 – miPASS4 Reader  
BioXK-6 – Custom MIFARE  
DESFire Reader

## DIAGRAM - BioXK

Diagrams are not to scale. Measurements are in millimeters (mm).

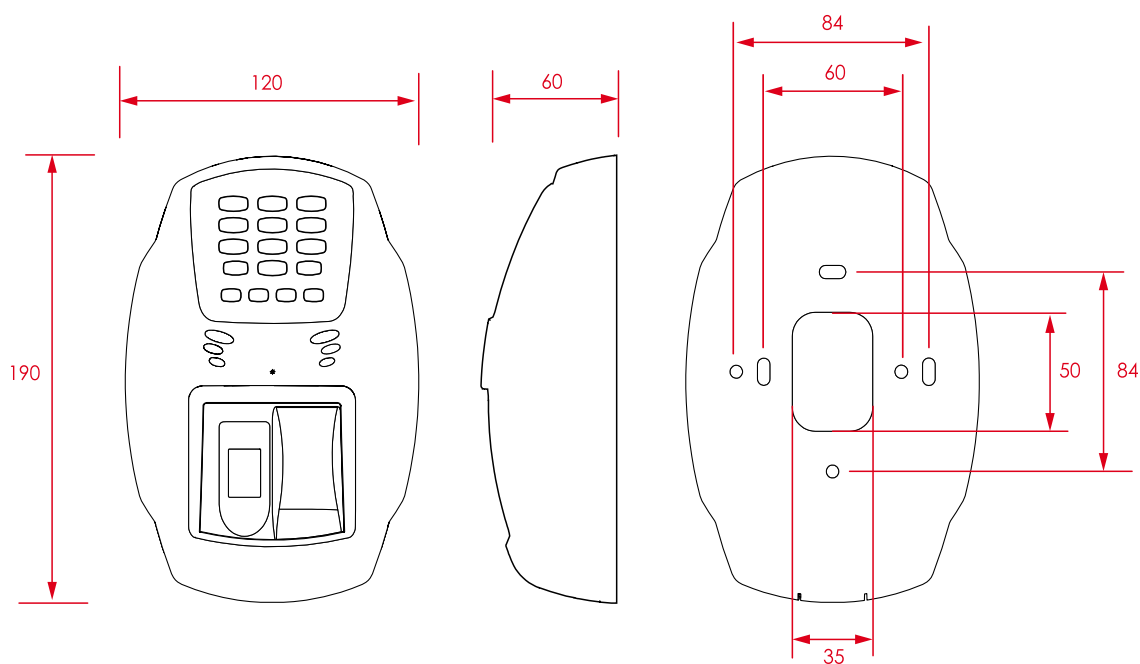

## MODEL COMPARISON

MODEL	BIOXK	IRIS ID - ICAM7000
<b>CREDENTIAL COMPATIBILITY</b>	MIFARE Classic, MIFARE DESFire EV1/EV2	MIFARE Classic, MIFARE DESFire EV1/EV2
<b>MOUNTING</b>	Mounting bracket	Flush or Recess Mounting
<b>CONNECTOR TYPE</b>	Flying lead	Power & ethernet ports (cable supplied)
<b>DIMENSION</b>	190mm (7.48") X 120mm (4.72") X 60mm (2.36")	178mm (7.01" ) X 211mm (8.31") X 64mm (2.52")
<b>COLOUR</b>	Charcoal	Black or Titanium
<b>OPERATING VOLTAGE RANGE</b>	8VDC to 16VDC	24VDC @ 1A or 12VDC @2A from power over ethernet (PoE)
<b>CURRENT DRAW (MAX)</b>	380mA	12~24 VDC, 2.0 Amps @ 12 VDC / 24W
<b>OPERATING TEMPERATURE RANGE</b>	-10°C to +50°C (+14°F to +122°F)	0°C to 45°C (32°F to 113°F)
<b>IP RATING</b>	IP65	IPXX
<b>BIOMETRIC SENSOR TYPE</b>	Optical (Morpho) Fingerprint	Face camera CMOS - 5MP IRIS
<b>FAKE FINGER DETECTION</b>	Yes	NA
<b>AUTHENTICATION MODES</b>	Template on Card Template and PIN on Card (Finger Only (1:N), Card + Finger (1:1), Card + Finger + PIN (1:1) available)	Template on Card Template and PIN on Card (Iris Only (1:N), Card +iris (1:1), Card + iris + PIN (1:1) available)
<b>ENROLMENT</b>	Integrated Reader/Enrolment Device	Separate (but interchangeable) enrolment & identification modes
<b>CONTROLLER COMMUNICATION</b>	Wiegand OSDP Encrypted RS485	Ethernet (LAN, WAN), RS232 RS485 RS422
<b>INPUT CONTROL</b>	Buzzer/LED external control	Customizable, colour LCD touch screen

## WARRANTY

Unless specified otherwise, the Company warrants to the Customer that 'BQT Solutions Branded Products' (excluding third party products and software) are covered by a return to base warranty on defects in materials and workmanship affecting normal use for a period of the Warranty offered under the Standard Terms and Conditions of Sale from BQT invoice date ('Standard Warranty')

Information obtained in this document is subject to change without notice. For further technical or sales information, visit our website at [www.bqtsolutions.com](http://www.bqtsolutions.com) or email [support@bqtsolutions.com](mailto:support@bqtsolutions.com)

© 2022 BQT Solutions (NZ) Limited. All rights reserved. BQT Solutions (NZ) Limited reserves the right to upgrade or change products or documentation without prior notice. An AVA Group Company.