

SIDELOAD LOCKS

YD30M

Cobalt - mini



Product Overview

The YD30M, also known as the Cobalt-mini, is a revolutionary low voltage motor-driven door lock for 90° doors. It has been designed to secure single acting doors and addresses the two biggest issues for electronic locking; the ability to align a misaligned door and the ability to release when requested, even with excessive load on the door.

The Cobalt-mini is typically used in commercial doors and controlled by access control systems. This gives the user the ability to control access in and around a facility and provide traffic reports when desired. Additionally, the Cobalt-mini can be used in a more straightforward system where controlling access to a single door can be implemented with a stand-alone access system.

Why BQT Solutions

BQT Solutions is a specialist in the development, manufacture and supply of high quality, high security card and biometric readers, electromechanical locks and related electronic security products. Providing high security solutions to verticals such as Airports, Hospitals, Prisons and Government for over 35 years.

Innovating today for a more secure tomorrow

Product Benefits

Benefit One

Engineered to release when requested even under significant side load pressure, something a traditional electromechanical lock won't. Side load pressure of up to 1,000N can be applied and the YD30M will still release if requested.

Benefit Two

Innovative in design, the Cobalt-mini lock will align a door that has trouble closing fully by correcting a misalignment of up to 8mm automatically. A common problem traditional electromechanical locks face is not being in the final position for the lock to work but the Cobalt-mini mitigates that risk by pulling the door in to ensure it closes fully and locks.

Benefit Three

Offering feedback to the control panel of the door and bolt positions is a standard feature of the YD30M. Monitoring the position of the door and whether the bolt pin is extended or retracted provides vital information needed to ensure a site is safe and secure.

Benefit Four

Flexibility in installation as the Cobalt-mini only requires low voltage power and signals to operate and can connect into any access system making wiring easy.

PRODUCT FEATURES

Sideload

World-leading in innovation and engineering, the unique design of the Cobalt-mini uses a collapsing mechanism that is deadbolted when locked but will unlock when requested even with 1,000N of force on the door.

Alignment

The pivot action of the Cobalt-mini bolt pin will 'grab' the strike plate and pull the door into position for a misalignment up to 8mm.

Fire Tested

The Cobalt-mini has been fire tested and approved for 30-minute, 60-minute, and 4-hour burn times to ensure our locks won't compromise a fire door's integrity or effectiveness.

High Security

With a 10mm thick stainless steel bolt pin, the Cobalt-mini has a holding force in excess of 10,000N. In addition, onboard control provides auto relock for added security.

Certified EN14846

Holding the EN14846 certification, the Cobalt-mini has been tested and awarded the European Standard for strength, security, durability, and function of electrical and electronic components for all types of electromechanically operated locks and striking plates used on doors, window doors and entrance doors in buildings.

Low Current Consumption

The Cobalt-mini will draw as little as 40mA in standby and only 300mA in operation at 12VDC. Low current paired with high-security access control makes the YD30M a preferred product choice for many industry leaders. Offering an eco-friendly and economical solution, the Cobalt-mini utilise a low power mode when in standby mode.

Integrated Access Control

With user-selectable fail-safe and fail-secure modes, and multiple attempts to lock or unlock, the YD30M is ready for a wide range of application requirements. It can be integrated easily with access control or alarm systems.

Versatile Installation

The Cobalt-mini can be morticed flush into both the side, or top of many door frames and comes with fitting tabs to make installation quicker. The lock is supplied with a matching strike plate as standard but additional items are available in the form of a housing and dress plate. These products allow the lock to be surface mounted when mortice installation isn't a preferred, or viable option. The housing and dress plates are supplied with self-adhesive tape for instant application to glass doors and door frames.

Durability

Tested for endurance for over 300,000 cycles, the Cobalt-mini offers durability and safety in medium volume traffic environments.

PRODUCT APPLICATIONS

Medium traffic volume, single acting pedestrian doors where door alignment or releasing when requested under sildeload is required. Commonly seen in mortice installations on office doors but also used on single acting glass doors where security is paramount, convenience required and appearances important. Used across all market sectors.



SPECIFICATIONS

- **Door Gap**
6mm maximum
- **Static Strength**
10,000 newtons (1,000Kg)
- **Sildeload (release on request)**
1,000 newtons (100Kg)
- **Endurance**
Cycle tested to 300,000 operations
- **Bolt Pin**
10mm thick, 13mm extension
- **Alignment**
8mm misalignment correction
- **Voltage at Lock**
12-24VDC \pm 15%
- **Current Usage**
Holding: 40mA@12V,
30mA@24V
Maximum: 1.0A@12V,
0.5A@24V
- **Monitor Switch Ratings**
24VDC, 0.5A
- **Materials**
Lock / Strike Plate: Stainless Steel 304
Bolt Pin: Stainless Steel 17-4PH
- **Compliance and Certification**
CE Compliant, RoHS 2 Compliant
FCC Part 15 Compliant
EN 14846:2008 Certified
Suitable for use on fire resistant doorsets
- **Lock**
YNL210H – Lock with Long Strike Plate
- **Accessories**
YNL213H – Long Strike Plate
YNL214J – Housing
YNL216J – Dress Plate

DIAGRAM - YD30M

Diagrams are not to scale. Measurements are in millimeters (mm).

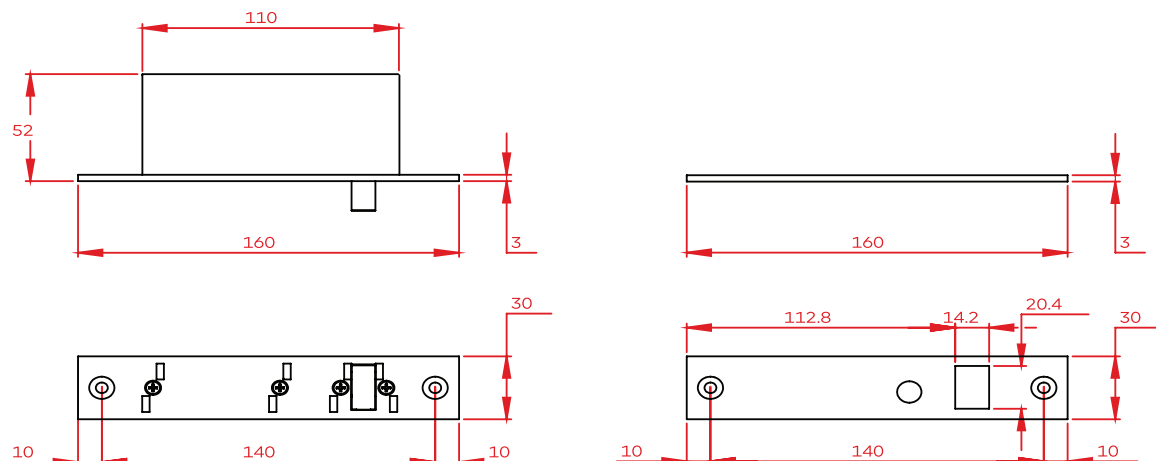

MODEL COMPARISON

NAME	APPLICATION	LIFECYCLE	HOLDING FORCE	LOCK DIMENSIONS	BOLT PIN DIMENSIONS	POWER USAGE
YD30 (COBALT)	Securing misaligned double acting doors, Releasing under sideload pressure	300,000	1000kg	255x30x51	10mm thick, 13mm extension (2 Pieces)	Input Voltage: 12-24VDC ± 15% Current (Stand By) 40mA - 30mA Current (Peak) 1A - 0.5A
YD30M (COBALT MINI)	Securing misaligned single acting doors, Releasing under sideload pressure	300,000	1000kg	160x30x51	10mm thick, 13mm extension	Input Voltage: 12-24VDC ± 15% Current (Stand By) 40mA - 30mA Current (Peak) 1A - 0.5A
YD25	Single Acting Doors	1,000,000	1000kg	210x25x42	12.7mm, 16mm extension	Input Voltage: 12-24VDC ± 15% Current (Stand By) 130mA - 80mA Current (Peak) 1A - 0.5A
YD25L	Double Acting Doors	1,000,000	1000kg	210x25x43	12.7mm, 16mm extension	Input Voltage: 12-24VDC ± 15% Current (Stand By) 130mA - 80mA Current (Peak) 1A - 0.5A
YD25K	Single Acting Doors	1,000,000	1000kg	210x25x44	12.7mm, 16mm extension	Input Voltage: 12-24VDC ± 15% Current (Stand By) 130mA - 80mA Current (Peak) 1A - 0.5A
YD38	Single Acting Doors	1,000,000	2000kg	203x37.5x44	14.2mm, 14mm extension	Input Voltage: 12-24VDC ± 15% Current (Stand By) 150mA - 90mA Current (Peak) 1A - 0.5A
YD38L	Single Acting Doors	1,000,000	2000kg	203x37.5x45	14.2mm, 14mm extension	Input Voltage: 12-24VDC ± 15% Current (Stand By) 150mA - 90mA Current (Peak) 1A - 0.5A
YG80	Securing all large openings, High strength, Extreme heat and cold environments	300000	5000kg	80x80x100	18mm, 30mm extension	Input Voltage: 12-24VDC ± 15% Current (Stand By) 40mA - 30mA Current (Peak) 1A - 0.5A - 2A with heater

WARRANTY

Unless specified otherwise, the Company warrants to the Customer that 'BQT Solutions Branded Products' (excluding third party products and software) are covered by a return to base warranty on defects in materials and workmanship affecting normal use for a period of the Warranty offered under the Standard Terms and Conditions of Sale from BQT invoice date ('Standard Warranty')

Information obtained in this document is subject to change without notice. For further technical or sales information, visit our website at www.bqtsolutions.com or email support@bqtsolutions.com