



YG80 Weatherproof Lock

Installation and Operating Instructions

DN 01015/001 - 03/2024

Table of Contents

1.	Document Information	3
1.1	Contents and Purpose	3
1.2	Target Group	3
2.	Safety and Compliance	4
2.1	Safety Information	4
2.2	Regulatory Compliance Information	5
3.	Product Information	7
3.1	Product Description	7
3.2	Package Contents	8
3.3	Technical Data	9
4.	Product Dimensions	10
4.1	Lock Dimensions	10
4.2	Strike Dimensions	11
5.	Pre-Installation	12
5.1	Mounting Assessment	12
5.2	Wiring Assessment	13
5.3	Operating Mode Assessment	14
5.4	Strike Configuration	15
6.	Mounting	16
6.1	Lock Installation	16
6.2	Strike Installation	17
7.	Wiring	18
7.1	Normal Mode (Fail Safe)	18
7.2	Normal Mode (Fail Secure)	18
7.3	Toggle Mode	19
7.4	Twin Wire Mode	19
7.5	Monitor Connections	19
8.	Operations	20
8.1	Operation Modes	21
8.2	Failure Modes	22
8.3	Heater Mode (Requires 24VDC Power Supply)	22
9.	Maintenance	23
9.1	Maintenance and Cleaning	23
9.2	End of Service Life	23

1. Document Information

1.1 Contents and Purpose

This document describes installation, connection, operation, and maintenance of the lock YG80. Read the document carefully and observe the instructions it contains. They contain important information for reliable installation and trouble-free operation.

1.2 Target Group

Target group of these instructions are:

- Installer
- Service Technician

Installers and service technicians are skilled personnel who have the specialist knowledge required for installation, commissioning, and maintenance.

2. Safety and Compliance

2.1 Safety Information



WARNINGS

- The handling and installation of this device is recommended for a professional.
- Use of an unsuitable power supply unit may cause product failure or injury.
- Operation of lock while submerged may cause product failure.
- Lock surface may become hot to touch when heater is active.



UL REQUIREMENTS

- If the unit is installed on a fire exit door the product installation shall be allowed only if accepted by a local AHJ authority having jurisdiction and comply with NFPA 101.
- The unit is to be connected and controlled via a UL 294 or FWAX7 listed Access Control Unit.
- That the unit shall be installed in accordance to NFPA 70 along with any additional requirements imposed by the local authority of jurisdiction.
- Do not connect the unit to a receptacle controller by a switch.
- If the unit is installed in conjunction with panic hardware the lock shall be installed in a manner to not impair panic device operations.
- The unit shall be powered by a UL 294 or UL 2610 listed power supply with a Class 2 power limited output.
- All factory tested grades were not evaluated by UL.

2.2 Regulatory Compliance Information



This product is in compliance with the CE Directives including Electromagnetic Compatibility (EMC) Directive, Restriction of the use of certain hazardous substances (RoHS) Directive, and Registration, Evaluation, Authorisation and Restriction of Chemicals (REACH) Regulation.

CE Declaration of Conformity is available at www.bqtsolutions.com.



This product is in compliance with the United Kingdom (UK) Legislation including the Electromagnetic Compatibility Regulation 2016, and the Restriction of the Use of Certain Hazardous Substances in Electrical and Electronic Equipment Regulations 2012.

UKCA Declaration of Conformity is available at www.bqtsolutions.com.



This appliance is labeled in accordance with European Directive 2012/19/EU concerning used electrical and electronic appliances (waste electrical and electronic equipment - WEEE). The guideline determines the framework for the return and recycling of used appliances as applicable throughout the EU.



In Countries Outside the European Union and EEA (Norway, Iceland, and Liechtenstein): If you wish to dispose of this product please contact your local authorities and ask for the correct way of disposal.



This product is in compliance with the Regulatory Compliance Mark (RCM) for Australia and New Zealand.



This product is regulated by the UL/CSA and bears UL/C-UL certification.

Certifications: UL294, UL1034, CSA C22.2

UL File Number: BP21205

UL Categories: ALVY, CVXY, UEHX7

UL294	Line Security Level I Standby Power Level I Attack Level I Endurance Level IV
UL1034	Static Strength: 1,500 lbf (6,673N) Dynamic Strength: 70 ft·lbf (95J) Endurance: 250,000 cycles



This device complies with Part 15 of the FCC Rules. Operation is subject to the following two conditions:

1. This device may not cause harmful interference.
2. This device must accept any interference received, including interference that may cause undesired operation.

Note: This equipment has been tested and found to comply with the limits for a Class B digital device, pursuant to Part 15 of the FCC Rules. These limits are designed to provide reasonable protection against harmful interference when the equipment is operated in a residential, commercial, or industrial environment. This equipment generates, uses, and can radiate radio frequency energy and, if not installed and used in accordance with the instruction manual, may cause harmful interference to radio communications. However, there is no guarantee that interference will not occur in a particular installation.

Modifications: Any modifications made to this device that are not approved by the manufacturer may void the authority granted to the user by the FCC to operate this equipment.

Innovation, Science and Economic Development Canada ICES-003:
CAN ICES-3(B)/NMB-3(B)

3. Product Information

3.1 Product Description





The YG80 is a low-voltage motor-driven heavy-duty lock suited for securing gates, roller doors, shipping containers, semi-trailers, and any other large door or entryway. The YG80 is designed to be weatherproof, low maintenance, and easy to install. It is supplied with a matching strike and can be installed externally or internally in a horizontal or vertical position. An 18mm diameter stainless steel bolt pin ensures the highest strength while a bolt pin extension of 30mm offers flexible installation.

Integrated electronics provide complete control over the lock and offer an array of features;

- Multi-voltage input (12 - 24VDC)
- Ingress protection to IP67
- Built-in heater for colder climates
- Multiple locking / unlocking attempts
- Multiple control methods
- Fail Safe / Fail Secure user selection with a single switch
- Door position monitoring
- Bolt locked and Bolt unlocked monitors
- Tamper Detection monitoring

The lock is fully sealed around the bolt pin and lid to prevent water ingress. For the wiring, waterproofing is ensured with a removable IPX7 rated cable.

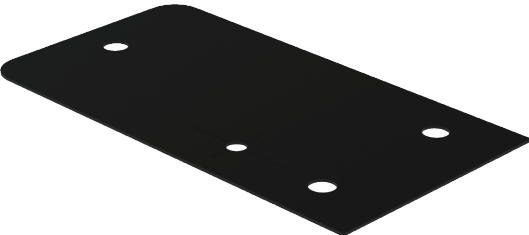
3.2 Package Contents

1x Lock	1x Strike
	
1x Neoprene Gasket (Optional Use)	1x 3 metre 8-way wire loom
	

3.3 Technical Data

Materials		
Bolt Pin	Stainless Steel SS304	
Lock / Strike Body	Aluminium A383	
Mechanical		
Bolt Pin Dimensions	ø18mm, 30mm extension, ø28mm receiver	
Strike Gap	max. 15mm (5/8 inch)	
Holding Force	39,000N (8,800 lbf) (factory tested only)	
Cycle Life	300,000 cycles	
Locking/Unlocking Time	4.5 seconds (typical)	
Environmental		
Operating Temperature	-35°C to +70°C (-31°F to +158°F)	
Ingress Protection	IP67 Rated	
Corrosion Resistance	240 hours salt spray (EN 1670:2007; Grade 4)	
Cold Resistance	-35°C (-31°F) for 2 hours (EN 60068-2-1:2008)	
Dry Heat Resistance	+70°C (+158°F) for 2 hours (EN 60068-2-2:2008)	
Electrical		
Power Requirements	12-24 VDC ±15%	
	Initial Power Up Time	25 seconds
	Initial Power Up Current	1A@12VDC, 0.5A@24VDC
	Standby Current	40mA@12VDC, 30mA@24VDC
	Heater On Current	2.0A@24VDC (only 24VDC)
Signal Contacts	Bolt Position (NO)	24VDC max., 250mA max.
	Door Position (NO)	
Compliance		
CE, UKCA, UL, FCC, IC, RCM, RoHS		

4. Product Dimensions

4.1 Lock Dimensions

The dimensions shown are approximate and subject to change without prior notice.

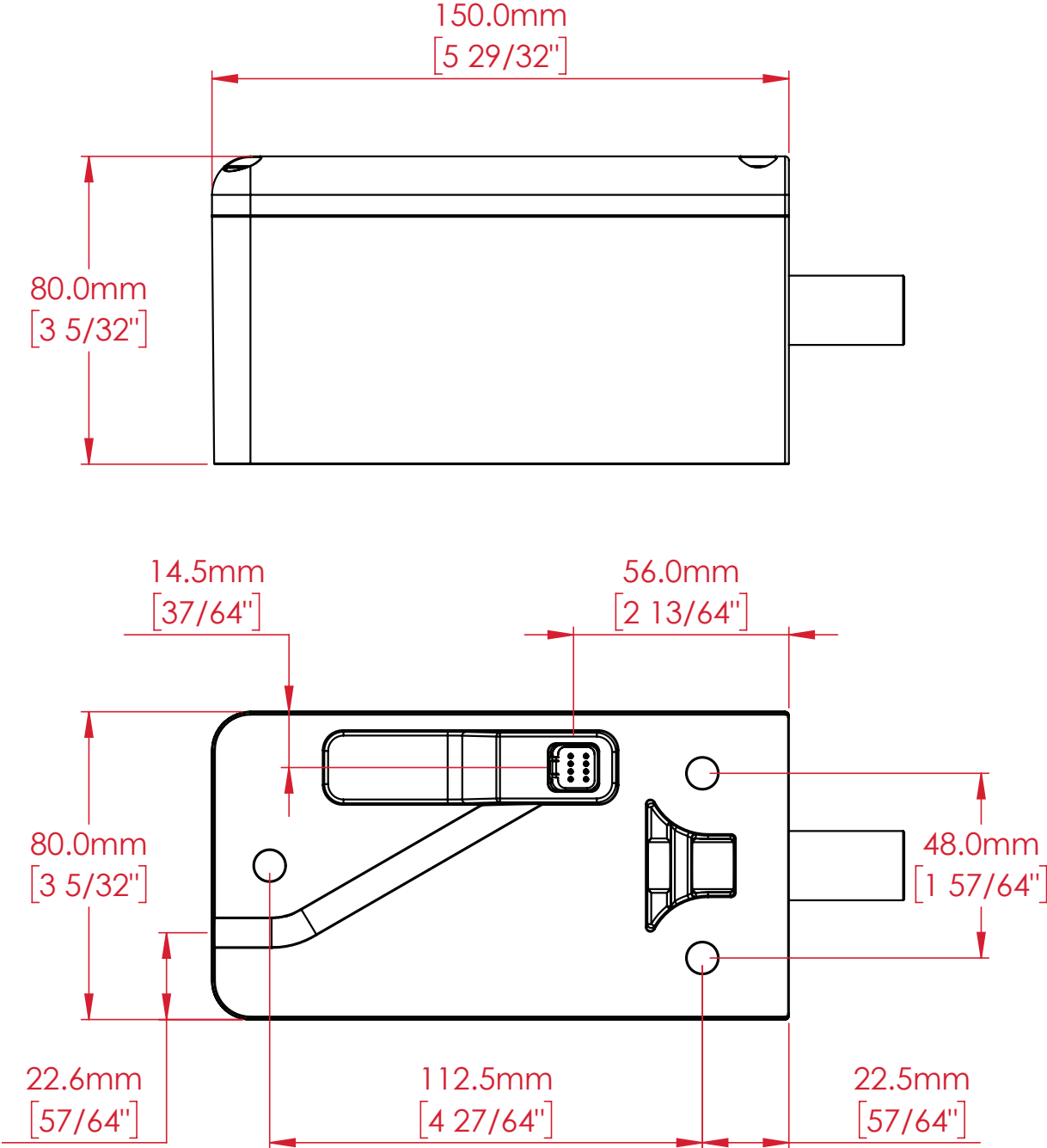

4.2 Strike Dimensions

The dimensions shown are approximate and subject to change without prior notice.

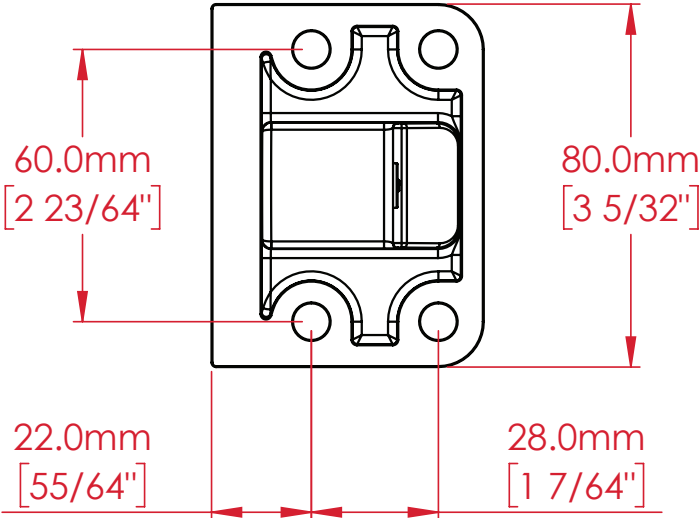
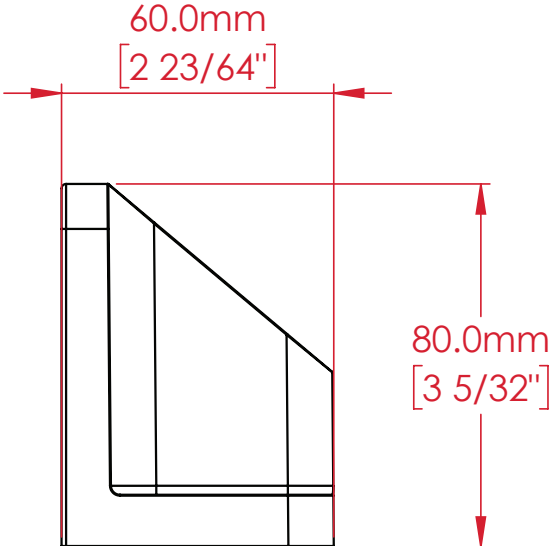

5. Pre-Installation

5.1 Mounting Assessment

Before the lock can be installed, consider its location and orientation. The YG80 can be mounted horizontally or firing downwards vertically, however mounting it firing upwards vertically may deteriorate the bolt pin seal faster **and will void warranty**.



Lock mounted to the ground.



Lock mounted to the wall horizontally.



Lock mounted to the wall with bolt pin vertically down.



DO NOT mount the lock with bolt pin vertically up.

Because the YG80 can be installed onto various mounting surfaces, with different requirements for fasteners depending on the surface material, **no mounting bolts are supplied**. The three mounting holes in the lock and four in the strike are 8mm holes, and so accept M8 size fasteners (or $\frac{5}{16}$ inch).

When positioning the strike, it is important to achieve a reasonable level of alignment with the bolt pin as to ensure correct locking and operation. The hole in the strike is of a larger diameter than that of the bolt pin, however installing the strike so the bolt pin goes into the hole centrally is best as it will allow for movement of the door over time. To ensure the YG80 operates properly, the lock and strike must be separated by **15mm or less ($\frac{5}{8}$ inch or less)**.

The adjustable nature of the strike means that the supplied magnet can be inserted in the desired location for all operating conditions, meaning the strike can approach from either the right, left, top, or bottom face of the lock.

5.2 Wiring Assessment

Before installation begins, consideration must be made for where to run the wires and decide on what feedback is required from the lock. There are a total of eight available connections; four are used for power/control connections whilst the remaining four provide optional door position, bolt position, and tamper detection feedback. These optional connections can be integrated into access control or alarm systems to provide full monitoring.

The correct gauge of wire needs to be chosen as voltage drop across the power/control wires can limit the locks operation. For all the remaining connections, a lower gauge wire can be used as these are only signal wires. The following table shows the maximum distance that the wire runs can be between the power supply and the lock, assuming the power supply outputs 12VDC or 24VDC.

Conductor Cross Sectional Area		Maximum Distance	
#AWG	(mm ²)	at 12VDC	at 24VDC
24	0.20	10m (33ft)	30m (98ft)
22	0.33	16m (52ft)	48m (157ft)
20	0.52	26m (85ft)	77m (253ft)
18	0.82	41m (135ft)	122m (400ft)
16	1.31	65m (213ft)	195m (640ft)
14	2.08	103m (338ft)	310m (1017ft)

The cable is detachable, and can either be run out of the base of the lock into the mounting surface or follow the channel in the base and be run out of the back end of the lock. If the cable is being run through the mounting surface, an additional hole is needed in the mounting surface for the cable to be pulled through (refer to dimension drawing for hole location).

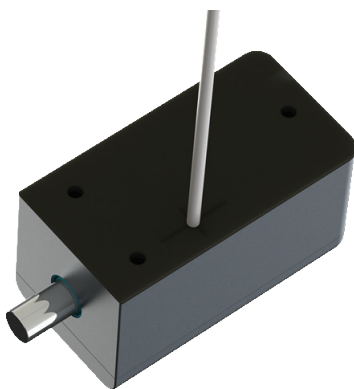

Cable being run out through the neoprene gasket to pass through mounting surface.

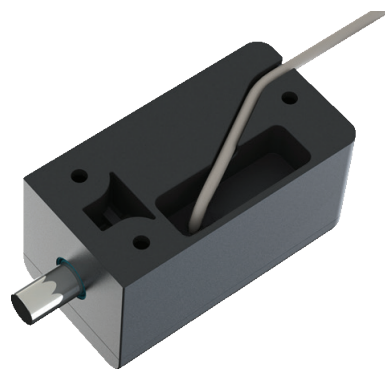

Cable being tracked through the channel and out the back of the lock for use with conduit.

5.3 Operating Mode Assessment

The YG80 can be set to one of three operating modes, one of two failure modes, and have the heater set on or off. These can be set by changing the dip switches on the product before or after installation.

The lock can be set to either normal mode, toggle mode, or twin wire mode. Deciding which operation mode is appropriate will depend on the control hardware being used with the YG80.

- **For normal mode**, the control input is set either high or low, and this will correspond to whether the YG80 is locked or unlocked. The controller or button will need to go high or low to trigger an unlock, and held there for the desired window to open the door.
- **For toggle mode**, the control input is provided a positive pulse, and this will correspond to the YG80 locking or unlocking. The YG80 will change states between locked and unlocked on every pulse.
- **For twin wire mode**, two control inputs are used. When control input 1 is provided a positive pulse the YG80 will lock, when control input 2 is provided a positive pulse the YG80 will unlock.

The lock can also be set to either fail safe, or fail secure. Deciding this will depend on how the lock should behave when there is power loss.

- **For fail safe**, the control input is set high to lock the door, and the YG80 will unlock in the event of power loss.
- **For fail secure**, the control input is set low to unlock the door, and the YG80 will lock or remain locked in the event of power loss.

The lock can also utilise a heater. Deciding whether to have the heater active will depend on the YG80 installation location and climate. If there is potential for ice to accumulate on the bolt pin, having the heater set on will ensure the YG80 can continue to operate.

5.4 Strike Configuration

The YG80 strike can be mounted a number of ways in relation to the lock, but to do so the embedded magnet must be moved to align with the YG80s internal reed sensor. Consider the magnet location for the following mounting orientations.

When the strike is oriented 90 degrees counter-clockwise to the lock, the magnet should be in the right slot.

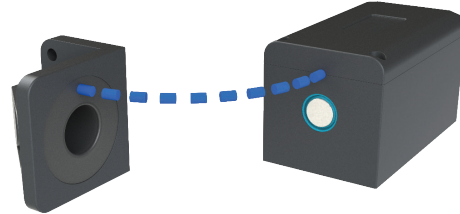

When the strike is oriented in the same plane as the lock, the magnet should be in the top slot.

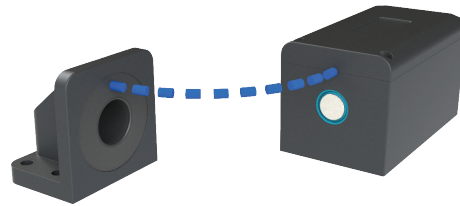

When the strike is oriented 90 degrees clockwise to the lock, the magnet should be in the left slot.

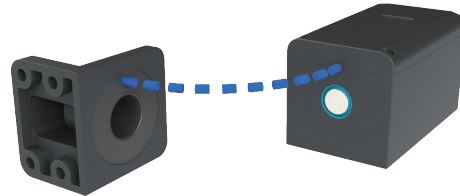

Strike Dissassembly

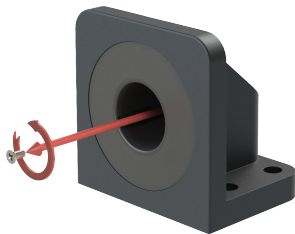

Remove the screw securing the strike ring with a #2 Phillips screwdriver.

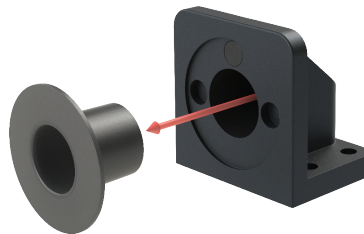

Slide the strike ring off of the strike to reveal the magnet.

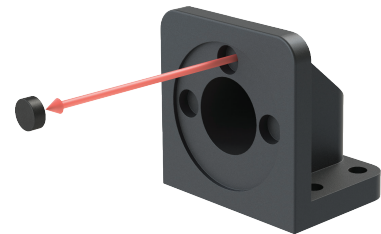

Carefully remove the exposed magnet by tipping the strike over, or using the tip of the screwdriver.

Strike Reassembly

Re-insert the magnet into the appropriate hole, such that when the door is closed the magnet is in the hole closest to the lid of the lock, then fit the strike ring back into position and secure with screw.

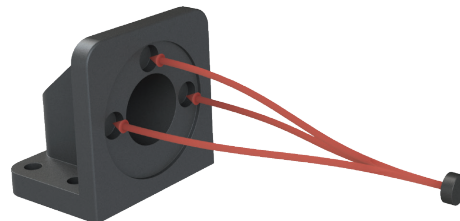

6. Mounting

6.1 Lock Installation

1. Drill the lock mounting holes

Referring to the product dimension drawings, drill holes at the mounting locations to accept the appropriate M8 screws for the surface material (*screws not included*). In the example shown, M8 stud anchors are used in a precast concrete wall.

2. Wiring the lock

Pull the required cable either through a hole in the mounting surface aligned with the connector port of the lock, or through a fixed conduit up to the opening at the back of the lock (refer to dimension drawings). A connection can be made to the supplied wire loom which in turn plugs into the lock. Ensure there are no sharp edges the wire loom can be cut on, use a grommet or similar as required.

If the neoprene base is being used, ensure the wire loom is passed through the neoprene base before mounting the lock, or push the wire loom into the track under the neoprene base, depending on the wiring pathway.

Refer to the Wiring section of this document for detailed instructions on wiring.

3. Setting the operating mode

Ensure the DIP switches are set to the desired operation mode.

Refer to the Operation Mode section of this document for detailed instructions on setting the operation mode.

4. Mounting the lock

The lock can be positioned over the mounting holes, with the neoprene base in between if being used. Take care to keep the wiring clear of being crushed by the lock when mounting. With the lid removed, insert and tighten the mounting hardware to secure the lock into place.

Place the lid back onto the lock and tighten up the lid screws using a 4mm hex key. To ensure a good even seal between the lid and lock body, partially tighten all four screws first before completely tightening them.

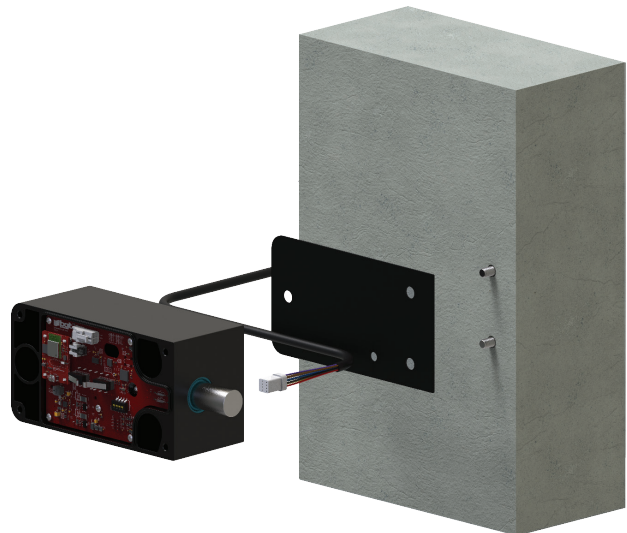

6.2 Strike Installation

1. Drill the strike mounting holes

Referring to the product dimension drawings, drill holes at the mounting locations to accept the appropriate M8 screws for the surface material (*screws not included*). In the example shown, 8mm holes are drilled and tapped in the aluminium box section of a gate.

Ensure that the lock and strike are aligned vertically and horizontally when the door is closed as this aligns the bolt pin to the strike opening and also the strike magnet to the locks internal door position sensor.

Ensure that the final gap between the lock and strike once it is installed will be no more than 15mm ($\frac{5}{8}$ inch).

2. Configure the strike

Ensure the magnet has been moved to the correct location to suit the mounting orientation of the lock and strike.

Refer to the Strike Configuration section of this document for detailed instructions on assessing and configuring the strike.

3. Mounting the strike

The strike can be positioned over the mounting holes. Insert and tighten the mounting hardware to secure the strike into place.

You can verify the placement and configuration of the strike by closing the door and removing the lid of the lock. If the YG80 detects the magnet, the **RED** LED will light up. Otherwise if it does not light up, the gap between the lock and strike may be too large or the magnet may not be in the correct location under the strike ring.



7. Wiring

The YG80 is supplied with an 8-way wire loom that plugs directly into the lock. The wires are colour coded as per table below, with the power and control wires being essential connections and the four monitor connections being optional.

Wire Colour	Meaning	Description
RED	Power Supply (12 - 24VDC)	Positive connection to DC power supply, "+".
BLACK		Negative connection to DC power supply, "-", common contact for monitors.
BLUE	Control 1	Switched positive control input.
BROWN	Control 2	Switched positive control input, for twin wire mode.
PURPLE	Door Position	Normally open contact (NO), closed when the strike is aligned with the lock.
ORANGE	Bolt Locked	Normally open contact (NO), closed when the bolt is extended.
YELLOW	Bolt Unlocked	Normally open contact (NO), closed when the bolt pin is retracted.
GREEN	Tamper Detection	Normally closed contact (NC), open when the lid is removed or wires cut.

7.1 Normal Mode (Fail Safe)

When in Fail Safe configuration, applying positive voltage to the blue control wire will trigger the YG80 to lock (active-high locking signal). In the event voltage is removed from the control line, the YG80 will unlock.

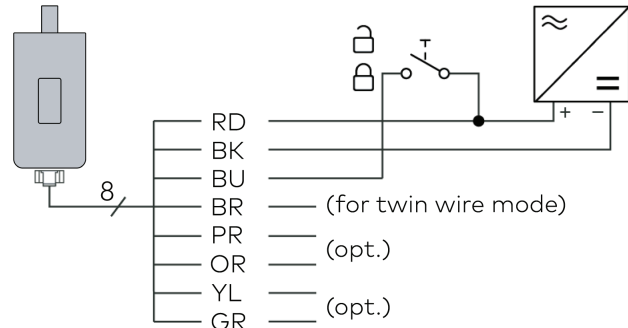

7.2 Normal Mode (Fail Secure)

When in Fail Secure configuration, applying positive voltage to the blue control wire will trigger the YG80 to unlock (active-low locking signal). In the event voltage is removed from the control line, the YG80 will remain locked.

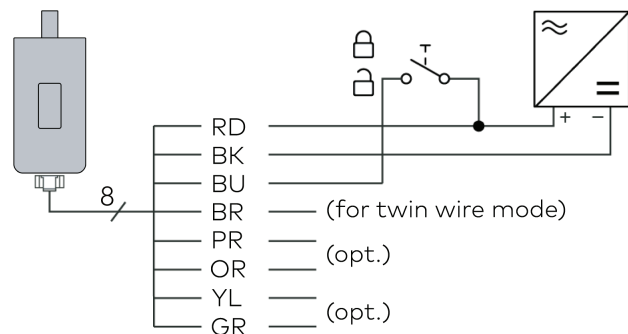

7.3 Toggle Mode

When in Toggle Mode, applying a short pulse of positive voltage to the blue control wire will trigger the YG80 to change its locking state. If it is locked, the YG80 will unlock; if it is unlocked, the YG80 will lock.

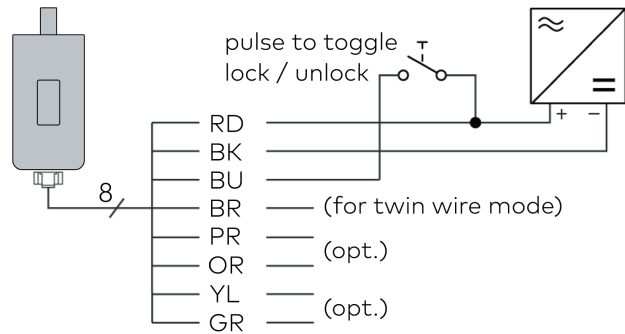

7.4 Twin Wire Mode

When in Twin Wire Mode, applying a short pulse of positive voltage to the blue control wire will trigger the YG80 to lock, and applying a short pulse of positive voltage to the brown control wire triggers the YG80 to unlock.

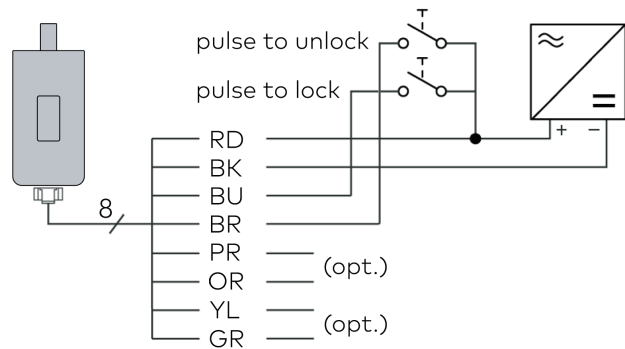

7.5 Monitor Connections

The YG80 has four optional monitor connections. They are all dry contacts, using the black negative supply wire as the common contact.

- **Door Position:** When the door is closed and the strike is aligned with the lock, the purple door position monitor wire will be in a closed contact state. When the door is open, the wire will switch to an open contact state.
- **Bolt Locked:** When the YG80 bolt pin is completely extended and therefore the door is locked, the orange bolt locked monitor wire will be in a closed contact state. When the bolt begins retracting, the wire will switch to an open contact state.
- **Bolt Unlocked:** When the YG80 bolt pin is completely retracted and therefore the door is unlocked, the yellow bolt unlocked monitor wire will be in a closed contact state. When the bolt begins extending, the wire will switch to an open contact state.
- **Tamper Detection:** When the lid is on the YG80, the green tamper detection monitor wire will be in a closed contact state. If the lid is removed in any way, the wire will switch to an open contact state.

8. Operations

To change operational modes, remove the lid and locate the DIP switches as shown below. Change the switches to the desired positions, as per the table shown.

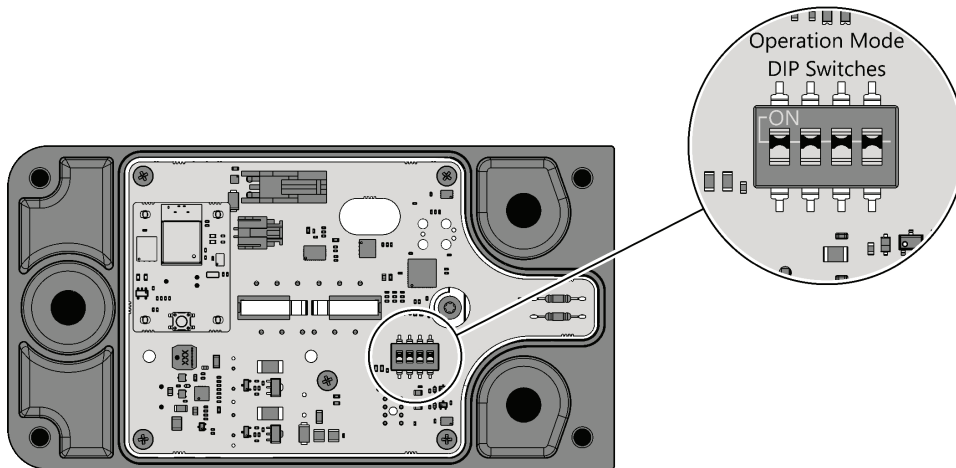

DIP Switch #				Description
1	2	3	4	
OFF	OFF	X	X	Normal Mode Operation
OFF	ON	X	X	Toggle Mode Operation
ON	OFF	X	X	Twin Wire Mode Operation
ON	ON	X	X	Diagnostic Mode Operation
X	X	OFF	X	Fail Safe Mode
X	X	ON	X	Fail Secure Mode
X	X	X	OFF	Heater Off
X	X	X	ON	Heater On (Requires 24VDC to be supplied)
X	X	X	TOGGLE	Next Diagnostic Test (Diagnostic Mode Only)

8.1 Operation Modes

Normal Mode (Fail Safe)

Assume the lock is installed, wired, and set to normal mode and fail safe. The door is open and the positive supply voltage is **applied** to the **BLUE** wire. When the door is closed the YG80 senses the strike and activates the bolt pin. If the bolt pin is obstructed during locking, the YG80 will attempt three times to lock before returning to the unlocked state.

To unlock the door, the voltage is **removed** from the **BLUE** wire. The YG80 will unlock and the door can then be opened. If the door is not opened before voltage is reapplied to the **BLUE** wire, the YG80 will re-lock.

Normal Mode (Fail Secure)

Assume the lock is installed, wired, and set to normal mode and fail secure. The door is open and the positive supply voltage is **removed** from the **BLUE** wire. When the door is closed the YG80 senses the strike and activates the bolt pin. If the bolt pin is obstructed during locking, the YG80 will attempt three times to lock before returning to the unlocked state.

To unlock the door, the voltage is **applied** to the **BLUE** wire. The YG80 will unlock and the door can then be opened. If the door is not opened before voltage is removed from the **BLUE** wire again, the YG80 will re-lock.

Toggle Mode

Assume the lock is installed, wired, and set to toggle mode. The door is closed and locked and a positive pulse is applied to the **BLUE** wire, the YG80 will unlock and the door can then be opened. While the door is open a second positive pulse is applied to the **BLUE** wire, when the door is closed the YG80 senses the strike and activates the bolt pin. If the bolt pin is obstructed during locking, the YG80 will attempt three times to lock before returning to the unlocked state.

The lock will continue to change between locked and unlocked for every pulse applied.

Twin Wire Mode

Assume the lock is installed, wired, and set to twin wire mode. The door is closed and locked and a positive pulse is applied to the **BROWN** wire, the YG80 will unlock and the door can then be opened. While the door is open a positive pulse is applied to the **BLUE** wire, when the door is closed the YG80 senses the strike and activates the bolt pin. If the bolt pin is obstructed during locking, the YG80 will attempt three times to lock before returning to the unlocked state.

Applying a pulse to the **BLUE** wire will set the YG80 to lock regardless of previous state. Applying a pulse to the **BROWN** wire will set the YG80 to unlock regardless of previous state.

Diagnostic Mode

There are six tests which can be cycled through by toggling the position of the fourth dip switch **ON** or **OFF**. The **YELLOW** LED will blink based on what test number you are on. Once testing has been completed, ensure all four of the dip switches have been returned to their original operating position.

Test	Name	Description
1	Cycle Count	The RED LED lights up if the cycle count is below 300,000 cycles.
2	Motor Health	After 3 test cycles, if the LED goes RED the motor is in good health.
3	Power Supply	After 10 seconds, if the LED goes RED the power supply is suitable.
4	Control 1	The RED LED lights up whenever the Control 1 input is active.
5	Control 2	The RED LED lights up whenever the Control 2 input is active.
6	Hall Sensor	The RED LED lights up whenever the strike magnet is detected.

8.2 Failure Modes

Fail Safe

In the event of a power failure, the YG80 will unlock. This ensures safe passage in emergency situations, as well as access when power is unavailable.

Fail Secure

In the event of a power failure, the YG80 will lock, or remain locked, if the door is closed. This ensures that a lock will not disengage during power failure, keeping the access secured.

8.3 Heater Mode (Requires 24VDC Power Supply)

The heater mode allows the YG80 to be used in colder climates, where the bolt pin can become iced over. When the heater mode is enabled, the YG80 will automatically activate the heater to ensure the lock is operating above freezing conditions. The heater will self-regulate and only be active when it is needed to conserve energy.

9. Maintenance

9.1 Maintenance and Cleaning

The lock has been factory lubricated for life and is maintenance free. The use of other lubricants is not permitted and will void the warranty.

With the lid removed it is important to take care when selecting the configuration or interacting with the printed circuit board.

This lock contains electromechanical and electronic components that are subject to wear and tear depending on use and on-site installation conditions. The manufacturer has no influence on these factors. As a result of this wear, the lock may fail at the end of its normal service life.

Interval	Activity
As needed:	To keep the YG80 working effectively, ensure the strike hole and bolt pin are clear of debris at all times.
Periodically, depending on frequency of use (to be determined by the operator):	Check for: <ul style="list-style-type: none">• Tight fit• Smooth running• Noise during operation• Play of the bolt• Contamination• Escaping lubricant• Moisture If there are unusual noises, noticeable play, escaping lubricant or similar; replace the lock.

9.2 End of Service Life

Running the diagnostic mode is a crucial step in assessing the health of a product. This mode allows for the identification of any test failures, which could indicate underlying issues. For example, should the diagnostic indicate the rated cycle count is surpassed or signal poor motor health, it implies potential concerns with the motor's condition. Similarly, a report of a bad power supply, despite using a reliable power source and wiring, or any input/output (IO) failures, are clear indicators that the product is not functioning as intended.

To prevent any unforeseen problems in the field, it's essential to conduct these diagnostic checks regularly. By doing so, any potential issues can be detected and addressed early on, thereby avoiding more significant problems later. If the diagnostics reveal any critical failures, it is considered to have reached the end of its service life and should be retired accordingly. This proactive approach ensures reliability and maintains the integrity of the product's performance over time.